



Operating and Installation Instructions Coffee System



To prevent accidents and appliance damage
read these instructions **before** installation or use.

Contents

IMPORTANT SAFETY INSTRUCTIONS	5
Preparing your appliance for an extended vacation	9
Guide to the coffee system	10
Accessories	12
Operation	13
First steps to use	17
Turning on	17
Water hardness	18
Filling the water tank	20
Filling the coffee bean container	21
Turning the coffee machine on and off	22
Dispenser adjustment	23
Preparing beverages	24
Espresso, Coffee or Lungo coffee	24
Preparing two portions	24
Canceling preparation	25
Preparing multiple cups of coffee, one directly after another (Coffee pot ).	25
Preparing coffee drinks from ground coffee	25
Beverages with milk	27
Instructions for the milk container	27
Preparing hot water	28
Preparing drinks using a profile	28
After preparing drinks	28
Customizing your coffee	29
Grinder setting	29
Changing the drink parameters	30
Amount of ground coffee	30
Brewing temperature	30
Pre-brewing ground coffee	31
Setting the serving size	32
Resetting drinks	34

Profiles	35
Accessing profiles	35
Creating a user profile	35
Selecting a user profile	35
Changing the name	35
Deleting a user profile	35
Changing a profile	36
Editing drinks for a profile	37
Creating a drink	37
Changing a drink: Changing the portion size, drink parameters and name	37
Deleting a drink	37
MyMiele	38
Settings	39
Accessing the "Settings" menu	39
Changing and saving settings	39
Overview of the Setting options	40
Language	42
Time	42
Date	42
Timers	43
Eco mode	44
Lighting	45
Starting screen	45
Info (displaying information)	45
Locking the coffee system (System lock )	45
Water hardness	46
Brightness	46
Volume	46
Activating and deactivating the plumbed water supply	46
Adjusting the dispensers	46
Factory default settings	46
Showroom program (demo mode)	46

Contents

Cleaning and care	47
Overview	47
Rinsing the system.	49
Milk pipework.	49
Rinsing the milk pipework manually	49
Cleaning the milk pipework using the milk line cleaner	50
Milk container with lid	51
Main dispenser	52
Cleaning the milk valve	54
Sensor cover	54
Water tank	55
Waste unit	55
Drip tray	56
Drip tray cover	57
Bean container.	57
Main dispenser connector.	57
Interior and front door	58
Brew unit	58
Removing the brew unit and rinse it by hand	58
Degreasing the brew unit	60
Exterior.	61
Descaling	62
Frequently asked questions	64
Cleaning clogged milk pipework	74
After sales service	77
Installation instructions	78
Caring for the environment	79
Plumbing	80
Lead free certificate	82
Electrical connection	83
Installation	84
Ventilation	86
Installation	86
Adjusting the door hinges.	88
RemoteVision (optional accessory)	89
Copyright and licenses	90
Contact details	95

IMPORTANT SAFETY INSTRUCTIONS

When using electrical appliances basic safety precautions should always be followed, including the following:

Read all instructions before installation or use of the coffee system.

Please read these instructions carefully to prevent accidents and machine damage.

This appliance complies with current safety requirements. Improper use of the appliance can cause personal injury and material damage.

This appliance is for household use only, to prepare espresso, cappuccino and coffee. Do not use this appliance other than for its intended use. Any other use could be dangerous.

The manufacturer cannot be held responsible for damage caused by improper use of the appliance.

Proper use

- ▶ This coffee system is for household use and similar indoor environments only. This coffee system is not suitable for outdoor use.
- ▶ Use this coffee system only in standard household environments for making coffee beverages such as espresso, cappuccino, latte macchiato, etc. Any other type of use is not permitted.
- ▶ Persons which lack physical, sensory or mental abilities or experience with the machine should not use it without supervision or instruction by a responsible person.

Children in the household

 The coffee and hot water dispensers present a danger of burning or scalding! Children's skin is more sensitive to high temperatures than that of adults. Keep children from touching the hot parts of the coffee machine or exposing parts of their bodies to the dispensers.

- ▶ Keep the coffee system out of reach of children.
- ▶ Always supervise children in the vicinity of the coffee machine. Do not allow children to play with the unit.
- ▶ Danger of suffocation! Children could become entangled in packaging (e.g. cling film) while playing or pull it over their heads and suffocate. Keep the packaging away from children.

IMPORTANT SAFETY INSTRUCTIONS

Technical safety

- ▶ Installation work and repairs must only be performed by a trained technician in accordance with national and local safety regulations. Repairs and other work by unauthorized persons could be dangerous and may void the warranty.
- ▶ A damaged coffee system can be dangerous. Before installing the coffee machine, check for externally visible damage. Do not operate a damaged unit.
- ▶ Be certain your appliance is properly installed and grounded by a qualified technician. To guarantee the electrical safety of this appliance, continuity must exist between the appliance and an effective grounding system. It is imperative that this basic safety requirement be met. If there is any doubt, have the electrical system of the house checked by a qualified electrician.
- ▶ To prevent damage to the coffee machine, make sure that the connection data on the data plate (fuse rating, voltage and frequency) matches the electrical power supply. Check this before connecting the machine. If in doubt, contact a qualified electrician.
- ▶ Do not use an extension cord to connect the appliance to electricity. Extension cords do not guarantee the required safety of the appliance (danger of overheating).
- ▶ For safety reasons, this coffee machine may only be used once it has been safely installed.
- ▶ If the machine is installed in combination with other appliances, a protective base should be installed between the appliance and the unit.
- ▶ The coffee machine must not be used in mobile installations such as boats.
- ▶ Only use the coffee machine in ambient temperatures between +50°F/10°C and +100°F/38 °C.
- ▶ Ensure that there is sufficient ventilation around the coffee machine. The ventilation openings in the surrounding cabinets and the space below the ceiling must be at least 78 3/4"² (200 cm²). Otherwise condensation can form, causing damage to the coffee machine or the surrounding cabinets.
- ▶ Do not place on or near a hot gas or electric burner, or in a heated oven.
- ▶ If the coffee system is installed in a closed kitchen cabinet, use it only with the cabinet door open. Do not close the cabinet door when the coffee system is in operation.
- ▶ The water supply must be accessible after installation.
- ▶ Only use Miele original spare parts. Only then can the manufacturer guarantee the safety of this machine.
- ▶ Do not damage or kink the cover of the water intake hose.

IMPORTANT SAFETY INSTRUCTIONS

▶ The integrated waterproof system will effectively protect the machine from water damage if the following conditions are met:

- The coffee machine is installed correctly (electricity and water supply).
- The coffee machine is immediately repaired if any damage is detected.
- The water supply is shut off during extended periods of non-use (e.g. vacation).

▶ Before service or maintenance disconnect the power supply by either removing the fuse, “tripping” the circuit breaker or unplugging the unit.

▶ Never open the outer casing of the appliance. Tampering with electrical connections or components and mechanical parts is dangerous and may cause machine damage.

▶ Do not let cord hang over edge of table or counter, or touch hot surfaces.

▶ To reduce the risk of injury, do not drape cord over the counter top or table top where it can be pulled on by children or tripped over unintentionally.

▶ To protect against fire, electric shock and injury to persons do not immerse cord, plugs, or coffee machine in water or other liquid.

Proper use

 The coffee and hot water dispensers present a danger of burning or scalding! The dispensed liquids and steam are extremely hot. The water in the drip tray may be very hot as well. Be careful when emptying it.

Please note:

- Keep away from the areas under the coffee and hot water dispensers when beverages or steam are being dispensed.
- Do not touch hot surfaces. Use handles or knobs.
- The spouts can spray hot liquid or steam. Be sure the main dispenser is fitted correctly and only use it if it is clean.

 Never look into the lighting directly or with an optical instrument.

▶ Do not use the coffee machine to clean objects.

▶ Before the first use, clean the coffee system and milk container thoroughly (see "Cleaning and care").

IMPORTANT SAFETY INSTRUCTIONS

▶ Please note the following regarding water:

- Without a plumbed water supply:
Only fill the water tank with cold, fresh tap water. Hot water or other liquids can damage the coffee system.
- Change the water every day to prevent a build-up of bacteria. When using a plumbed water supply: Empty the water tank once a day.
- Do not use mineral water. Mineral water will cause a lot of limescale to build up in your coffee system and damage it.
- Do not use water from reverse osmosis units. This could damage the appliance.

▶ Fill the bean container with roasted whole coffee beans only. Do not fill the bean container with coffee beans which have been treated or with ground coffee.

▶ Do not use raw coffee beans (green, unroasted coffee beans) or coffee blends that include raw coffee. Raw coffee beans are very hard and contain moisture that will damage the grinder.

▶ Sugar will destroy the system! Do not use coffee beans which have been treated with caramel, sugar, etc. or fill the coffee system with other liquids that contain sugar.

▶ Do not fill anything into the ground coffee chute except ground coffee or a Miele cleaning tablet for degreasing the brew unit.

▶ Do not use flavored ground coffee in the machine. The sugar content on these grounds clogs the brew unit of the machine. The cleaning tablet is not enough to remove the residue.

▶ Only use plain milk. Most additives contain sugar, which will clog the milk pipework and damage the coffee system.

▶ If you use dairy milk, use only pasteurized milk.

▶ Never place a cup with a burning alcohol-coffee mixture underneath the main dispenser. This could cause the plastic parts of the coffee system to catch fire and melt.

▶ Do not lean on the open coffee machine door, or apply any pressure to it. Otherwise, the coffee machine could be damaged.

▶ The use of accessory attachments not recommended by the appliance manufacturer may result in fire, electric shock or injury to persons.

IMPORTANT SAFETY INSTRUCTIONS

► Please note the following with regard to cleaning the coffee machine:

- Before cleaning and maintenance switch off the appliance and disconnect circuit breaker.
- Clean the coffee system and milk container daily (see "Cleaning and care").
- The steam dispensed by a steam cleaner can reach the electrical components and cause a short circuit.
Never use a steam cleaner to clean the coffee machine.
- Descale the coffee machine regularly with the appropriate number of Miele descaling tablets for the water hardness level in your area. Descale the machine more frequently in areas with very hard water.
- Degrease the brew unit regularly with the supplied Miele cleaning tablets. Depending on the natural oil content of the coffee used, the brew unit can become blocked quite quickly.
- The main dispenser connector cap is lubricated with silicone grease. Be careful of your clothing when removing or inserting containers or other inside components .

For machines with stainless steel trim:

► Do not use sticky notes, transparent adhesive tape, masking tape or other types of adhesive on the surface of the trim. These damage the surface, causing it to lose its dirt repellent protective coating.

► The surface of the stainless steel trim is susceptible to scratching. Even magnets can cause scratches to appear.

Preparing your appliance for an extended vacation

► If you elect to turn off the water to your home for an extended period of time, please note that this may not be enough to reduce the risk of a leak. To be completely safe, you must turn off the water supply to each individual appliance. This means under the sink for a dishwasher, at the laundry bib for your washer, etc.

SAVE THESE INSTRUCTIONS

Guide to the coffee system

Front view

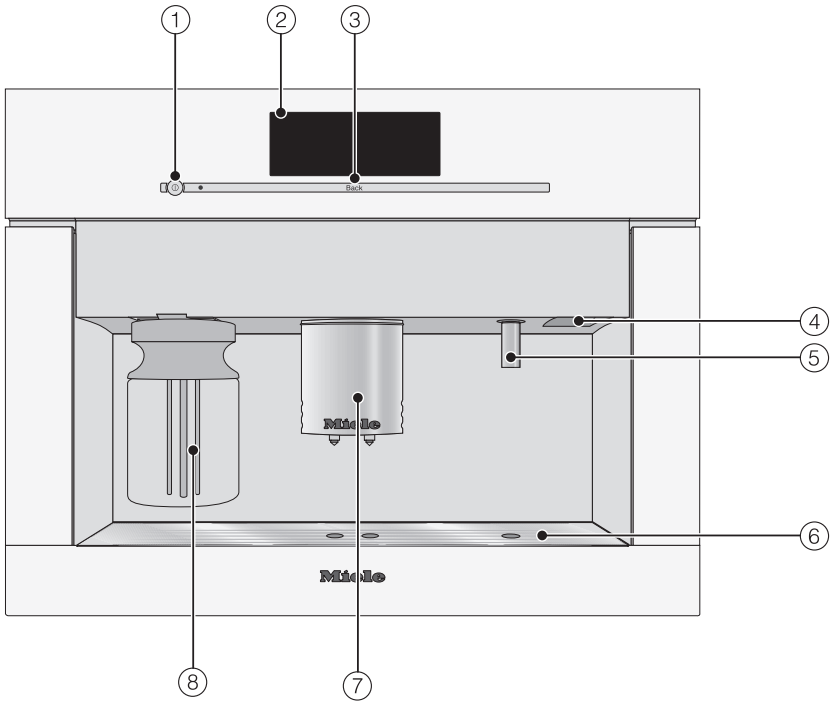

- ① On/Off touch control ①
- ② Touch display
- ③ "Back" sensor
- ④ Door handle
- ⑤ Hot water dispenser
- ⑥ Drip tray
- ⑦ Main dispenser, with automatic height-adjustment and lighting
- ⑧ Milk container with lid

Interior view

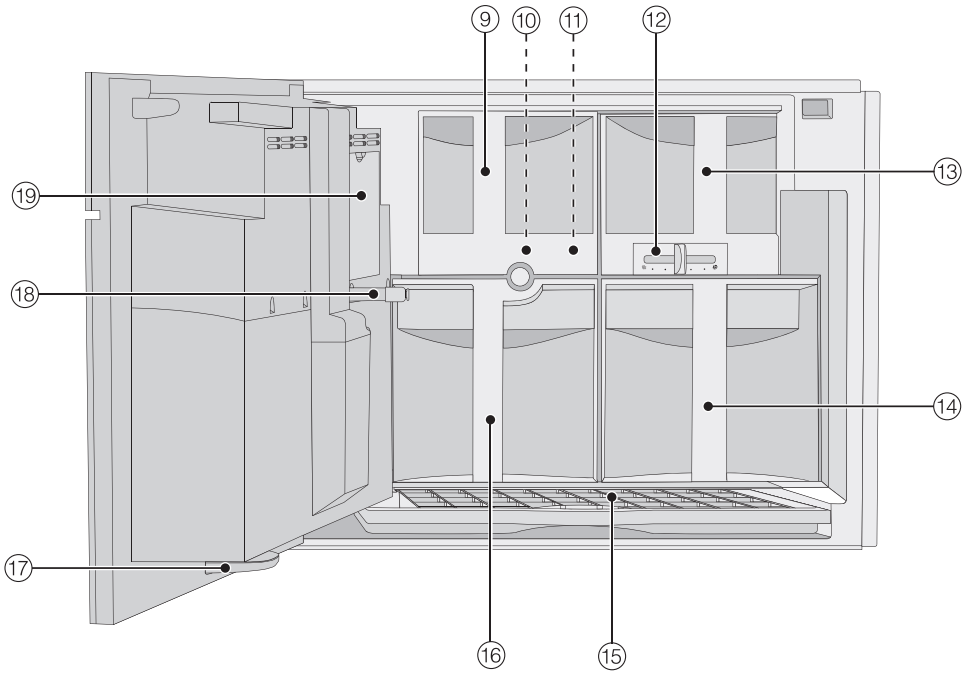

- ⑨ Ground coffee chute cover
- ⑩ Brew unit
- ⑪ Ground coffee chute
- ⑫ Grind control lever
- ⑬ Coffee bean container
- ⑭ Water container with inlet
- ⑮ Drip tray with no-spill grid
- ⑯ Waste unit
- ⑰ Drip catcher
- ⑱ Main dispenser connector cap
- ⑲ Service cover

Accessories

Included accessories

- **Coffee scoop**
for measuring ground coffee
- **Milk container with lid**
for storing and preparing milk
- **Compact seal**
Milk container lid for storage in the fridge
- **Milk pipework cleaning agent**
for cleaning the milk system (starter kit)
- **2 cleaning containers** (large, small)
for cleaning and care
- **Descaling tablets**
for descaling the water pipes (starter kit)
- **Cleaning tablets**
for degreasing the brew unit (starter kit)
- **Test strips**
for determining the water hardness
- **Cleaning brush**
for cleaning the milk pipework
- **Silicone grease**
for lubricating the main dispenser cap connector
- **Main dispenser cap connector**
spare part
- **Milk pipework angle section**
spare part

Optional accessories

Miele offers a range of useful accessories, as well as cleaning and conditioning products for your coffee machine.

- **All-purpose micro fiber cloth**
for removing fingerprints and minor contamination
- **Milk container with lid**
for storing and preparing milk
- **Milk pipework cleaning agent**
for cleaning the milk system
- **Descaling tablets**
for descaling the water pipes
- **Cleaning tablets**
for degreasing the brew unit
- **Silicone grease**
for lubricating the main dispenser cap connector

Additional accessories are available. Contact Miele or visit the Miele website for more information.

Touch display

The coffee system is operated by a finger touch.

If your fingers are cold, the touch display may not react to your finger contact .

Do not use pointed or sharp objects, e.g. pens, to operate the touch display. This can damage the surface! The touch display will not react if you tap it with such objects.

Do not let water get behind the display.

Display

The screen is divided into three areas:

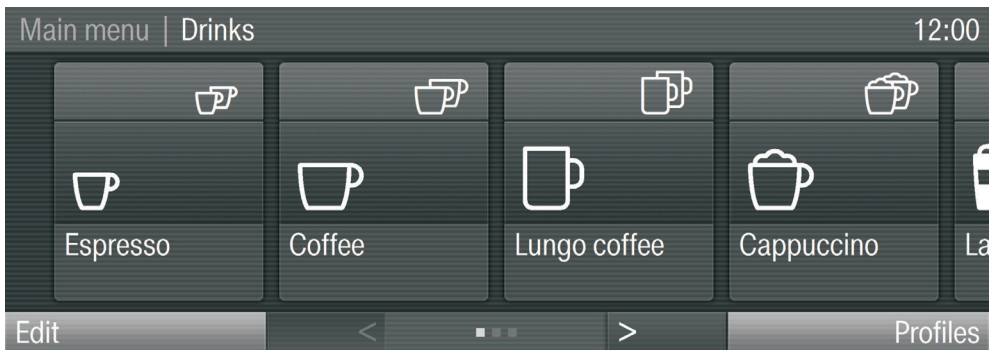

The top line shows you where you are in a menu. Touching the name of the desired menu will open the menu. Touching "..." will return you to the previous menu. The time of day is displayed on the right hand side.

The control field is in the middle: The current menu and options are displayed there. The < and > arrows are used to scroll to the right or left and select various actions.

On the bottom line you can go to the displayed menus by touching the desired gray field.

The number of boxes in the middle indicates the number of available pages in the current menu.

Operation

Using the touch display

Each finger touch of an available option changes the respective field to **orange**.

Selecting or calling up a menu

- Touch the respective field once.

Scrolling

- Swipe the screen, i.e. place your finger on the touch display and swipe it in the desired direction.

You can scroll to the right or the left. Some menu options allow you to scroll up and down too.

- Touch the < and > arrows to scroll to the left or right.

Exiting a menu ("Back" sensor)

Touch the "Back" sensor to go back to the previous screen. Entries made before this which have not been confirmed with "OK" will not be saved.

Touch the "Back" sensor three times to go to the drinks menu. Touch the "Back" sensor in the "Profiles" menu to go back step by step to the beginning.

Entering numbers using the numerical keypad

You can enter numbers by swiping and touching the digit rollers or via the numerical keypad.

Wait until the roller is gray. The entered setting will not be saved until it is gray.

- Touch .

The numerical keypad appears.

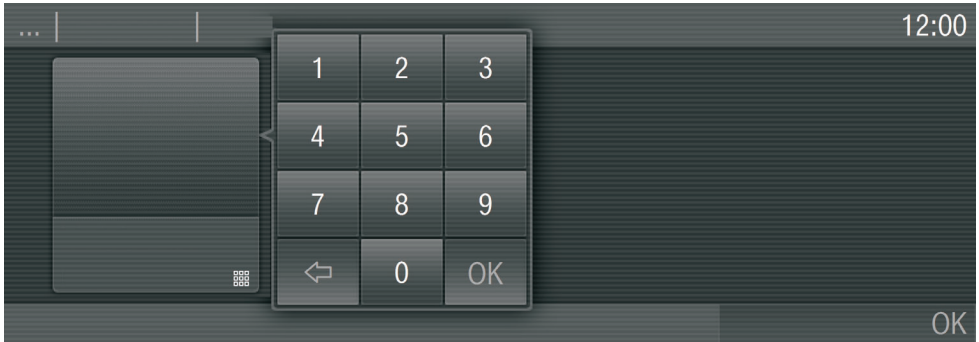

- Touch the desired numbers.

When you enter a valid number, the "OK" field will go green.

- Touch "OK".

Entering letters



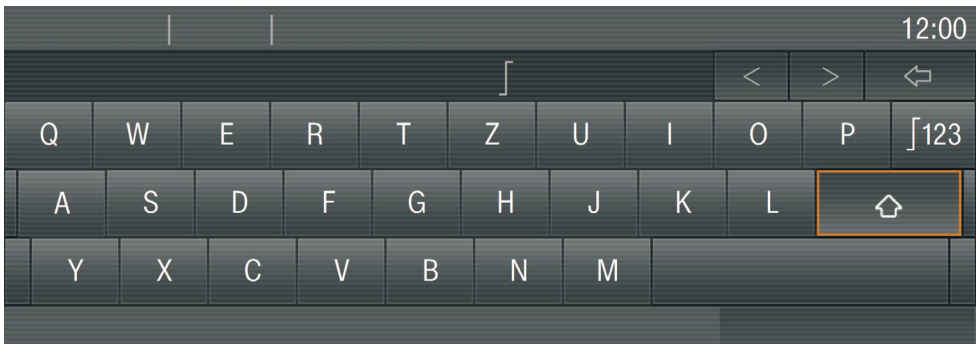



Profile names or the names for your own drinks are entered using a keyboard.



- Touch the desired letters or characters.
- Touch "Save".

Operation

The following symbols may appear in addition to the text and drinks symbols:

	Settings such as the brightness of the display or the volume of the audio signals are selected via a bar chart.
	Indicates information and instructions about operating the coffee system. Confirm the messages with "OK".
	The system lock is active (see "Settings - Locking the coffee system (System lock 
	The timer is activated for "Turn on at" (see "Settings - Timer"). The symbol and the desired turning-on time appear in the display 23:59 hours before the coffee system is due to turn on, as long as "On" or "Night dimming" is selected for the time display.
	This symbol appears when the milk pipework is being cleaned. (The symbol is also on the water tank: Fill the water tank up to this mark).
	This symbol appears when descaling is being carried out. (The symbol is also on the water tank: Fill the water tank up to this mark).

Before the first use

- The appliance must be correctly installed and connected before the first use. See the "Installation instructions".
- Remove any protective coverings.

Clean the coffee machine thoroughly (see "Cleaning and care") before filling it with water and coffee beans.

Turning on

When you turn the coffee machine on for the first time, you will be prompted to set the following after the welcome screen has appeared:

- Language
- Date
- Time of day
- Display (time of day)
- Touch the On/Off button .

The display briefly shows the "Miele - Welcome" message.

Setting the language

- Touch the desired language and then "OK".
- Touch the desired country and then "OK".

The setting is now saved.

Setting the date

- Swipe the "Day" field in the display until the current day appears.
- Repeat this for "Month" and "Year" until the current date is set.
- Touch "OK".

The setting is now saved.

Setting the time (of day)

- Swipe the "Hours" field in the display until the number for the current hour appears.
- Repeat this for "Minutes" until the current time of day is set.
- Touch "OK".

The setting is now saved.

First steps to use

Display

You can choose from the following options:

- **On:** The display will always show the date and time even when the system is turned off.
- **Off:** The display is dark when the system is turned off.
- **Night dimming:** The date and time are only displayed between the hours of 5 a.m. and 11 p.m.
- Touch the option you want and then "OK".

Depending on which option you select, the coffee machine may consume more energy. This is indicated by a message on the display.

"Set-up successful" appears in the display.

"Fill and replace the water container" appears in the display.

- Fill the water container with cold, fresh tap water.

Water hardness

Water hardness is an indication of the amount of minerals dissolved in water. The higher the mineral content, the harder the water. And the harder the water, the more often the coffee machine will need to be descaled.

The coffee machine monitors the quantity of water and steam used. The number of beverages that can be dispensed before the machine needs to be descaled will depend on the water hardness level set.

Set the water hardness level on the coffee machine to the water hardness level for the local area to ensure that the machine functions correctly and is not damaged. This will ensure that the reminder to descale the machine will appear in the display at the correct time. If unsure of your water hardness contact your local water authority.

You can program four hardness levels on the machine:

Water hardness	Hardness range	Setting (hardness level)
0 - 8.7 gr/gal (0 - 8.4°dH)	soft	soft 1
8.7 - 14.6 gr/gal (8.4 - 14°dH)	medium	medium 2
14.6 - 21.9 gr/gal (14 - 21°dH)	hard	hard 3
21.9 gr/gal (21°dH)	hard	very hard 4

Checking water hardness level

You can check the water hardness level using the supplied test strips.

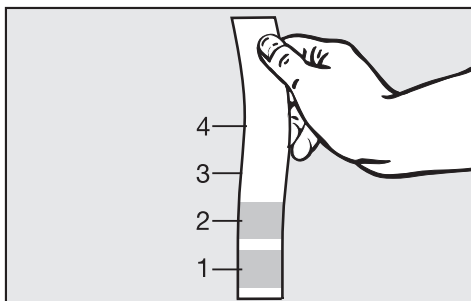

- Dip the test strip into your tap water for about one second. Then shake off any excess water. The result will be visible after about one minute.

You can now set the water hardness level for the coffee system.

Setting the water hardness

- Touch "Settings" .
- Swipe the display until "Water hardness" appears, and then touch it.
- Touch the hardness level you want and then "OK".

The setting is now saved.

Filling the water tank

If the coffee machine is connected to a plumbed water supply, the water is filled up automatically as soon as the machine is turned on.

The inlet guide at the water tank lid ensures that the water flows in quietly.

Of course, you can also fill the water tank manually when using the coffee machine without a plumbed water supply (water tank operation).

 Change the water **daily** to prevent bacteria growth.

Before using the coffee system for the first time, clean the appliance. See "Cleaning and Care".

Only fill the water tank with cold, fresh tap water.

Hot or warm water or other liquids can damage the coffee machine.

Do **not use mineral water** to fill the water tank. Mineral water will cause serious lime scale deposits to build up in your coffee machine and damage it.



- Open the unit door.

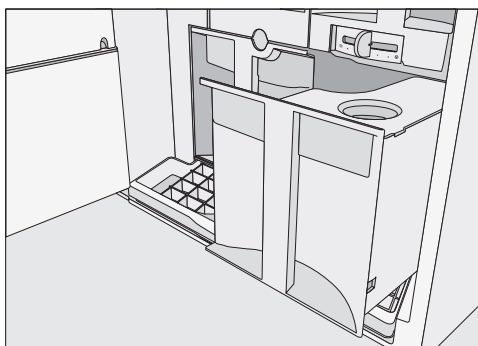

- Slowly pull the water tank forward and out.
- Remove the lid and fill the container with fresh, cold tap water to the "Max." mark.
- Push the water tank into the unit until it clicks into place.

If the water tank has not clicked into place, pull the tank out, check and clean the niche. The valve might leak. If necessary, clean the niche and surface.

Filling the coffee bean container

You can make coffee or espresso from roasted whole coffee beans that the coffee machine will grind fresh for each portion. Add fresh beans to the coffee bean container.

Alternatively, you can make coffee or espresso from ground coffee (see "Coffee beverages prepared from ground coffee").

Only fill espresso or coffee beans in the bean container. Anything else - including ground coffee - will damage the grinding unit.

Caramelized or otherwise pre-treated beans or sugar containing beverages must not be filled into the appliance. It will damage the coffee system.

Warning! Sugar will destroy the coffee system. Do not fill the machine with caramelized, sugar coated, pretreated beans or sugary liquids.

Do not use raw coffee beans (green, unroasted coffee beans) or coffee blends that include raw coffee. Raw coffee beans are very hard and contain moisture that will damage the grinder.

Tip: Raw coffee can be used if ground in a mill used for nuts or seeds. These mills generally have a rotating stainless steel blade. You can then use this coffee in the ground coffee chute and prepare the desired coffee drink (see "Preparing coffee drinks from ground coffee").

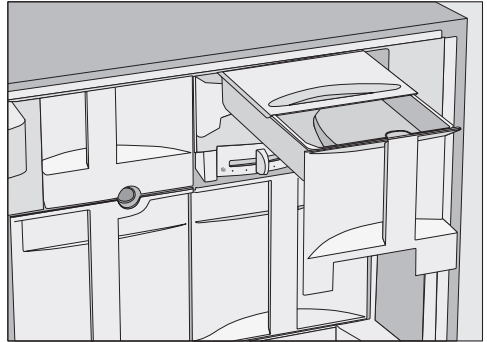

- Pull the bean container out.
- Slide the lid back, then fill the bean container with roasted coffee beans.
- Slide the cover all the way forward again.
- Slide the bean container back into the coffee machine.
- Close the door.

Turning the coffee machine on and off

Turning on

When the machine is turned on, it heats up and rinses out the pipework. This cleans and heats the pipework to ready the machine for coffee preparation.

If the coffee machine still has an operating temperature higher than 140°F (60°C), rinsing will not take place.

- Tap the On/Off button ①.

Tip: If you do not want the water from the rinsing process to flow into the drip tray, place a suitable container (such as the small cleaning container) underneath the coffee dispensers before preparing the first coffee of the day.

After heating up, the machine will rinse the pipes. Hot water will flow from the coffee dispensers.

Drinks can now be prepared.

Turning off

- Tap the On/Off button ①.

When a coffee beverage has been prepared, the coffee machine also rinses the coffee lines before turning off.

Turning off for longer periods of time

If you will not be using the coffee machine for a while:

- Empty out the drip tray, the waste unit and the water tank.

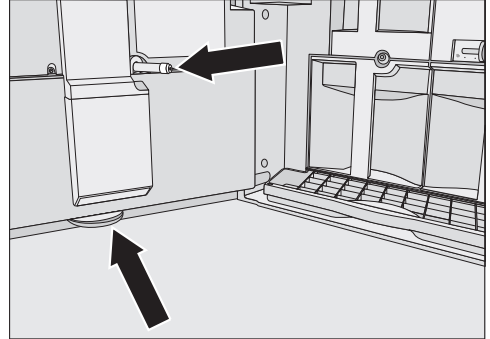

- Thoroughly clean all components including the brew unit, the main dispenser connector and the drip bowl in the door.
- Turn the machine off.

If you leave the door open for an extended period of time, unplug or disconnect it from the power supply to save energy.

The main dispenser **cannot** be adjusted manually.

The coffee system senses the height of the cup or glass being used. When a drink has been selected, the main dispenser automatically moves to the optimum height before dispensing the drink.

Make sure that there is not a spoon or stirrer in the cup. This would prevent the coffee system from sensing the cup height correctly.

You can turn off the automatic dispenser adjustment. The main dispenser will then remain in the upper position until the coffee system is turned off. When a maintenance program is being performed, the main dispenser moves to the height of the cleaning containers or into a maintenance position.

When the coffee system is turned off, the main dispenser moves to a middle position.

Turning the dispenser adjustment on or off

- Touch "Main menu" or the Back sensor.
- Touch "Settings" .
- Swipe the display until "Dispenser adjustment" appears, and then touch it.
- Touch the setting you want in order to turn the dispenser adjustment on or off.
- Touch "OK".

The setting is now saved.

Preparing beverages

Espresso, Coffee or Lungo coffee

From the "Drinks" menu:



- Place a cup under the main dispenser.
- Touch Espresso ☐, Coffee ☐ or Lungo coffee ☐.

The chosen coffee drink will now be dispensed.

To ensure that any residues from the factory testing process are removed from the brewing system, please discard the first two cups of coffee when using the system for the first time.

Preparing two portions

You can request two portions of espresso or coffee at once in one cup or in two separate cups simultaneously.

From the "Drinks" menu:

To fill two cups at the same time:



- Place a cup under each main dispenser nozzle.
- Touch the two-cup symbol for the drink you want.

Preparation begins and two portions of the desired drink will be dispensed from the main dispenser.

Canceling preparation

To cancel preparation,

- Touch "Stop".

or

- Touch "Cancel".

Preparing multiple cups of coffee, one directly after another (Coffee pot ☐)

You can use the "Coffee pot" function to prepare multiple cups of coffee, one directly after another (max. 1 l), in order to fill a coffee thermos, for example. You can prepare up to 8 cups this way.

- Place a suitably sized coffee pot or other container under the main dispenser.
- Swipe the display until "Coffee pot" ☐ appears and then touch it.
- Touch the number of cups you want (3 to 8).
- Follow the instructions on the display.

Each cup of coffee will be individually ground, brewed and poured. Each stage of the process is shown in the display.

You can cancel the process at any time:

- Touch "Cancel" or "Stop".

You can use the "Coffee pot" function twice in succession. After that, the coffee system will need to cool down for an hour to prevent damage to the appliance.

Preparing coffee drinks from ground coffee

To make espresso or coffee using ready ground coffee, add a portion of ground coffee to the ground coffee chute.

This allows you to prepare a decaffeinated coffee even if the bean container is already filled with regular coffee beans, for example.

The coffee machine will automatically recognize that ground coffee has been placed in the chute.

Only **one** portion of coffee or espresso can be prepared at a time when using ground coffee.

Preparing beverages

Adding ground coffee

Use the scoop supplied with the system to ensure the correct amount of ground coffee is used.

Do not add more than one level scoop of ground coffee to the coffee chute. If too much ground coffee is filled into the chute the brew unit cannot process it.

The coffee machine will use all the ground coffee that you have filled into the chute for the next coffee preparation.

- Open the front door of the coffee system.

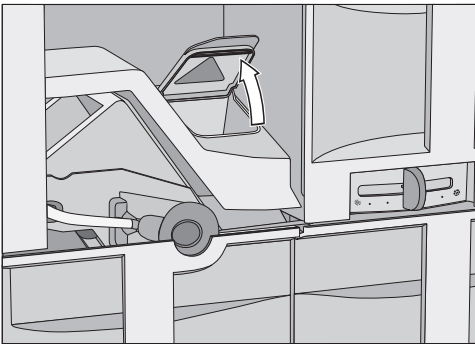

- Pull out the cover of the ground coffee chute. Open the lid of the ground coffee chute.
- Place a level scoop of ground coffee into the chute.
- Close the ground coffee chute and slide the chute cover back into the appliance. Close the front door.

The display shows the message "Use ground coffee?"

Preparing coffee drinks from ground coffee

If you want to use ground coffee:

- Touch "Yes".

You can now select which coffee drink you want prepared from the ground coffee.

- Place a cup under the main dispenser.
- Touch the drink you want.

The desired coffee drink will be prepared.

If you **don't** want to use ground coffee:

- Touch "No".

The ground coffee will be directed into the waste unit.

If a button is not pressed within approx. 15 seconds, the ground coffee is emptied into the waste unit.

Beverages with milk

You can prepare various specialty coffee beverages with milk or **Hot milk** and **Milk froth**.

The following specialty coffee options are available:

Cappuccino ☞ consists of about two-thirds milk froth and one-third espresso.

Latte macchiato ☞ consists of one-third each of hot milk, milk froth and espresso.

Café latte ☞ consists of hot milk and coffee.

Instructions for the milk container

The milk is **not** cooled in the milk container. If you do not prepare milk beverages for a while, place the milk container in the refrigerator. Good milk froth can only be prepared with cold milk (under 55°F / 13 °C).

Only use plain milk. Most sugary additives can clog the milk lines.

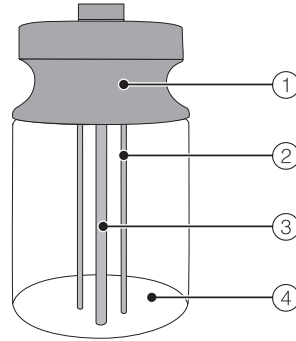

- ① Lid
- ② Sensor rod
- ③ Milk intake tube
- ④ Glass container

- Fill the milk container to a maximum level of 3/4" (2 cm) below the rim. Place the lid on the milk container.

Ensure that the neck and lip of the container are kept clean (both when filling and when moving the container). Contamination can cause malfunctions.

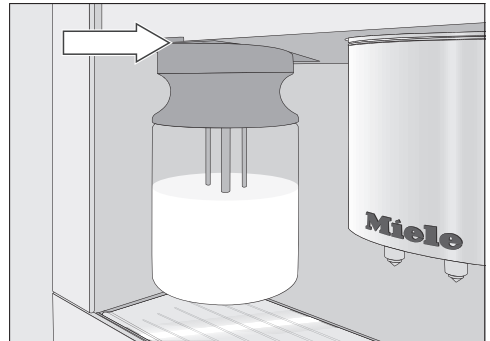

- Slide the milk container into the front of the coffee machine.

Preparing beverages

Preparing drinks with milk

From the "Drinks" menu:

- Place a suitable cup or glass under the main dispenser.
- Swipe the display until the desired drink appears and then touch it.

The drink will be prepared.

Preparing hot water

 Caution! Danger of scalding and burns! The dispensed water is very hot.

From the "Drinks" menu:

- Place a suitable cup or glass under the hot water dispenser.
- Swipe the display until "Hot water" appears, and then touch it.

Hot water is dispensed into the container under the hot water dispenser.

To cancel preparation:

- Touch "Cancel" or "Stop".

The coffee system cancels the preparation.

Preparing drinks using a profile

If you have already created a profile (see "Profiles"), you can select it before preparing a drink.

- Touch "Profiles"  and select the desired profile.

The profile name will appear in the display to show that a profile has been selected.

Now you can prepare your desired drink.

After preparing drinks

If you have prepared a drink with milk, "Start rinse cycle" will appear in the display after a while.

- Touch "OK".

The milk pipework will be rinsed.

Even if you do **not** confirm with "OK", the coffee machine will automatically rinse the milk pipework after a while.

Customizing your coffee

To customize the coffee system to suit your requirements, you can

- change the grinder setting,
- change the amount of ground coffee,
- change the brewing temperature, or
- turn on the "Pre-brewing" option.

Grinder setting

You can change the grinder setting to suit the type of coffee you are using.

When the beans are ground correctly the coffee or espresso will flow evenly into the cup and have a good crema.

The ideal crema has a hazel color.

There are various ways to tell whether the coffee grinder is set correctly.

The grind is **too coarse** if

- espresso or coffee flows into the cup too quickly;
- the crema is very pale and uneven.

Use a finer grinder setting so the coffee beans will be ground more finely.

The grind is **too fine** if

- espresso or coffee just drips into the cup;
- the crema is dark brown.

Use a coarser grinder setting so the coffee beans will be ground more coarsely.

To prevent damage to the grinder:

Adjust the coffee grinder one level at a time.

Grind the beans again before adjusting another notch.

- Open the front of the coffee system.

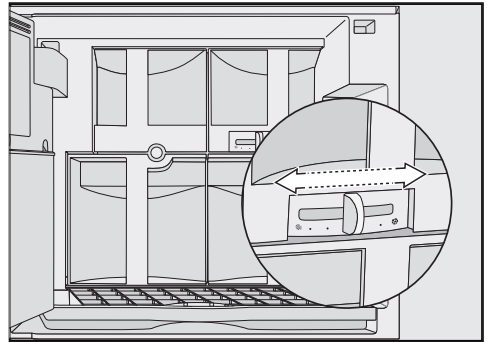

- Push the grind control slide to the left by no more than one increment (for a finer grind) or to the right (for a coarser grind).

- Close the front.

- Prepare a coffee beverage.

Then you can adjust the grinder by another increment.

The adjusted grinder setting will only take effect after the second coffee portion.

Customizing your coffee

Changing the drink parameters

You can change the amount of ground coffee, the pre-brewing and the brewing temperature for each drink individually.

From the "Drinks" menu:

- Touch "Edit" or swipe the display until "Make drinks" appears and then touch it.
- Touch "Change drink".
- Swipe the display until the drink you want appears and then touch it.
- Touch "Drink parameters".

You can now

- change the amount of ground coffee,
- change the brewing temperature, or
- turn on the "Pre-brewing" option.

Amount of ground coffee

The coffee system can grind and brew 6-14 g of coffee per cup. The greater the amount, the stronger the coffee or espresso.

There are various ways to tell whether the amount of ground coffee is set correctly:

The amount is **too small** if

- espresso or coffee flows into the cup very quickly,
- the crema is very pale and uneven,
- the espresso or coffee lacks body.

Increase the amount of ground coffee so that a stronger coffee is brewed.

The amount is **too much** if

- espresso or coffee just drips into the cup;
- the crema is dark brown;
- the espresso or coffee tastes bitter.

Decrease the amount of ground coffee so that a weaker coffee is brewed.

- Touch "Amount of ground coffee".
- Touch the bar for the amount you want and then "OK".

Brewing temperature

The ideal brewing temperature will depend on

- the type of coffee,
- whether an espresso or a coffee is being prepared, and
- the altitude of the region.

There are five brewing temperatures.

Tip: Not every coffee can tolerate high temperatures. Certain types are too delicate, so the crema on top is not as good and the taste is adversely affected.

- Swipe the screen in the "Brewing temperature" field until the setting you want appears.
- Touch "OK".

The setting is now saved.

Pre-brewing ground coffee

When the pre-brewing function is turned on, the freshly ground coffee is first moistened with a little hot water. Then the remaining water is forced through the moistened coffee at high pressure. This helps release the flavor of the coffee.

You can select short or long pre-brewing or turn off the "Pre-brewing" function.

The system is delivered with "Pre-brewing" turned off.

- Swipe the screen in the "Pre-brewing" field until the setting you want appears.
- Touch "OK".

The setting is now saved.

Setting the serving size

The flavor of a **coffee beverage** depends not only on the type of coffee, but also on the quantity of water used. You can adjust the amount of water used for each portion of espresso, coffee or hot water to suit your cup size and the type of coffee used.

For beverages prepared with milk, you can also adjust the milk and milk froth ratio in addition to the espresso or coffee size. You can also program the portion sizes of hot milk and froth.

There is a maximum amount which can be programmed for each type of drink. Preparation stops when this is reached. The maximum portion size possible for that type of beverage will then be saved.

The changed beverage size is always stored in the current profile. The name of the current profile is shown at the top left of the display.

If there is insufficient water in the water tank during preparation, the coffee system will stop the portion programming. The portion will **not** be saved.

From the "Drinks" menu:

- Place the desired cup under the main dispenser.
- Touch "Edit".
- Touch "Change drink".

■ Swipe the display until the beverage you want appears and then touch it.

- Touch ""Change the portion size".

The desired beverage is prepared and the display shows "Save".

- Touch "Save" when the cup has been filled to the desired amount.

If you want to change the portion size for **Cappuccino**, **Latte macchiato** or **Caffè latte** the ingredients which make up the drink will appear in the display.

Cappuccino: milk froth, espresso

Latte macchiato: hot milk, milk froth, espresso

Caffè latte: hot milk, coffee

- Touch the ingredients for which you want to program the portion size.

The selected ingredients have a check mark beside them.

- Touch "OK".

Setting the serving size

The coffee system will now start preparing your drink. Portion sizes can be set for each selected ingredient when "Save" is displayed.

- Touch "Save" when the correct amount of the particular ingredient has been dispensed.
- Save the portion size for the selected ingredients.

The programmed portion size and ingredients will now be dispensed every time that particular drink is selected.

Resetting drinks

You can reset the portion sizes and parameters for all drinks back to their factory default setting.

From the "Drinks" menu:

- Touch "Edit".
- Touch "Reset drinks".

"Reset all drinks to default?" appears in the display.

- Touch "Yes".

If the coffee system is used by several people with different coffee preferences, you can create individual user profiles. You can choose the serving size of each coffee beverage for each profile (see "Setting the serving sizes").

The name of the current profile is shown at the top left of the display.

Accessing profiles

- Touch  in the main menu or "Profiles" in the drinks menu.
- You can now create a profile.

If you have already created a profile in addition to the standard Miele profile, you also have the following options:

- **Select profile** from the pre-set profiles already created for the system.
- **Change name**, if you wish to change the name of a profile.
- **Delete profile** if you wish to delete a profile.
- **Change profile** to determine whether the coffee system automatically reverts to the standard Miele profile after each drink or continues to use the most recently selected user profile.

Creating a user profile

- Touch "Create profile".

The editor will open in the display.

- Enter the desired name and touch "OK".

Selecting a user profile

- Touch the desired profile.

The name of the current profile is shown at the top left of the display.

Changing the name

- Touch "Edit".
- Touch "Change name".
- Touch the desired profile and then "OK".
- Enter the desired name and touch "OK".

Deleting a user profile

- Touch "Edit".
- Touch "Delete profile".
- Touch the desired profile and then "OK".

Profiles

Changing a profile

You can customize the system so that after preparing each beverage it automatically reverts to the standard Miele profile or retains the most recently selected custom profile.

- Touch "Edit".
- Touch "Change profile".

You can now choose between:

- **Manually:** The system retains the selected profile until another profile is selected.
 - **After each use:** After each beverage is dispensed, the system automatically reverts to the standard Miele profile.
 - **When turned on:** Every time the system is turned on, it automatically selects the standard Miele profile, no matter which profile was selected before it was last turned off.
- Touch the option you want and then "OK".

Editing drinks for a profile

You can create your own beverages for each profile and set the portion size and parameters, e.g. amount of coffee, brewing temperature, for each beverage individually.

You can also change the names of the drinks and delete any unwanted drinks from the profile. A profile can contain a maximum of nine drinks.

- Touch "Profiles"  in the main menu or "Profiles" in the drinks menu.
- Select the desired profile.

The name of the current profile is shown at the top left of the display.

Creating a drink

You can create new drinks based on existing ones. A profile can contain a maximum of nine drinks.

The "Create drink" option will only appear if there are less than nine drinks in the profile.

- Touch "Edit".
- Touch "Create drink".

You can now select from the standard drinks:

- Swipe the display until the desired drink appears and then touch it.
- Change the drinks parameters and the portion size for this drink (see "Customizing your coffee" and "Changing the portion size").

Preparation will begin and you can save the amount of each individual ingredient as desired.

- Enter a name for the newly created drink (maximum of 8 characters) and touch "Save".

The newly created drink will appear in the profile.

Changing a drink: Changing the portion size, drink parameters and name

- Touch "Edit".
- Touch "Change drink".
- Swipe the display until the drink you want appears and then touch it.

You can now either change the portion size, drink parameters or name as described.

Deleting a drink

- Touch "Edit".
- Touch "Delete drink".
- Swipe the display until the drink you want appears and then touch it.
- Touch "OK".

MyMiele

Frequently prepared drinks, drinks from profiles and preferred maintenance programs can be displayed on the MyMiele screen.

You can select the MyMiele screen as your starting screen (see "Settings - Starting screen"). This screen is displayed each time you turn your coffee system on.

Accessing MyMiele

- In the main menu, touch "MyMiele" .

Now you can customize MyMiele and add entries.



If you have already created entries, you can select "Edit" to:

- sort entries or
- delete entries.

Adding entries

- Touch "Add entry".

You can add entries from:

- Drinks 
- Profiles 
- Maintenance 

- Touch the option you want and then "OK".

A tile is displayed showing the selected entry and the associated menu.

Deleting entries

- Touch "Edit".
- Touch "Delete entry".
- Select the entry you want to delete and confirm with "OK".

The entry is deleted.

Sorting entries

- Touch "Edit".
- Touch "Sort entries".
- Select one by one the entries you want to sort and insert them at the desired positions.
- Confirm each new position with OK.

The "Settings" menu allows you to customize the coffee system for your personal needs.

Accessing the "Settings" menu

You are in the "Drinks" menu.

- Touch "Main menu" or the Back sensor.
- Touch "Settings" .

Now you can check or change any settings.

Touch "Back" to return to the previous menu.

The settings which are currently selected have a colored frame around them.

Changing and saving settings

- Touch "Main menu" or the "Back" sensor.
- Touch "Settings" .
- Swipe the display until the setting you want appears and then touch it.
- Swipe the display until the option you want appears and then touch it.

The setting is now saved.

Settings

Overview of the Setting options

The factory setting for each menu item is shown in **bold**.

Option	Available settings
Language	German , other languages Country
Time	Display Off / On / Night shutoff Clock type Analog / Digital Time format 12 h / 24 h Set
Date	Set
Timer	Timer 1 Set Turn on at / Turn off after (0:30) / Turn off at Days of the week Monday / Tuesday / Wednesday / Thursday / Friday / Saturday / Sunday / Accept Activate Turn on at (Yes / No) / Turn off at (Yes / No) Timer 2 Set Turn on at / Turn off at Days of the week Monday / Tuesday / Wednesday / Thursday / Friday / Saturday / Sunday / Accept Activate Turn on at (Yes / No) / Turn off at (Yes / No)
Eco mode	Eco mode (On / Off)
Lighting	Brightness Turn off after
Starting screen	Main menu Drinks menu Profiles MyMiele
Info	Number of drinks Total no. of portions / espresso / coffee / lungo coffee / cappuccino / latte macchiato / café latte / milk froth / hot milk / hot water Portions until Descaling / Degreasing the brew unit
System lock	On / Off

Settings

Option	Available settings
Water hardness	Soft 1 Medium 2 Hard 3 Very hard 4
Brightness	Set
Volume	Audio signals Keypad tone
Plumbed water supply	On / Off
Dispenser adjustment	On / Off
Showroom program	Demo mode (On / Off)
Factory default settings	Settings MyMiele

Settings

Language

You can select your language and country for all the displayed text.

Tip: If you select the wrong language by mistake, follow the flag symbol  to return to the "Language" option.

Time

You can customize the time display, the time format and the time of day.

Display (time of day display)

You can choose from the following options:

- **On:** The time of day is always displayed even when the system is turned off.
- **Off:** The time of day is not displayed when the system is turned off.
- **Night shutoff:** The time is only displayed during the daytime.

Your selection affects the energy consumption of the coffee system. This is indicated by a message on the display.

Clock type

The time can be displayed as:

Analog or



Digital.

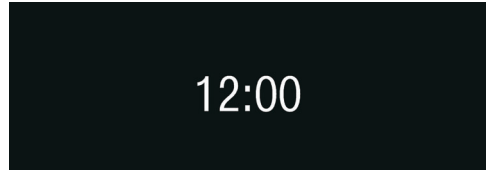

Time format

The options are:

- 24-hour clock (24 hr)
- 12-hour clock (12 hr)

Time

You set the hours and minutes.

Date

You set the day, month and year.

Timers

There are two timers with the following functions:

The coffee system

- turns on at a specific time, e.g. in the morning for breakfast ("Turn on at").
- turns off at a specific time ("Turn off at").
- turns off after a specific length of time if none of the buttons have been pressed and no drinks are being prepared ("Turn off after"; only available for Timer 1).

You can also assign the timer functions to individual days of the week.

For "Turn on at" and "Turn off at" the timer must be **activated** and **at least** one weekday must be assigned.

Selecting a timer

The options are:

- Timer 1:
Turn on at, Turn off at, Turn off after
- Timer 2:
Turn on at, Turn off at

Turn on at

If you have activated the system lock, the coffee system will **not** turn on at the specified time.
In this case the timer settings are deactivated.

If the coffee system has turned itself on automatically **three times** using the timer function "Turn on at" but no drinks

were dispensed, the system will not turn itself on again automatically. This prevents the coffee system from turning itself on unnecessarily, for example while you are away on vacation.

The programmed times will, however, remain in memory and will be reactivated after manually turning the system on again.

Turn off at

If you are away for a while, the stored times will be reactivated the next time the system is manually turned on (see "Turn on at").

Turn off after

The timer function "Turn off after" is only available with Timer 1.

If none of the sensors has been touched or no drink is being prepared, the coffee system will turn itself off after 30 minutes to save energy.

You can change this default setting and select a time between 15 minutes and 9 hours.

Settings

Assigning days of the week

Select the day of the week you want. The selected weekday is marked with a .

When all the desired weekdays are checked:

- Touch "OK".

Activating and deactivating a timer

If the timer for "Turn on at" is activated, the \oplus symbol and the desired turn-on time will appear on the display 23:59 hours beforehand if the time display has been set to "On" or "Night shutoff".

If the system lock has been activated, the timer function "Turn on at" cannot be selected.

Select the timer function you want. The selected timer function is marked with a .

When all desired timers are checked:

- Touch "OK".

Eco mode

Eco mode is an energy-saving mode. The steam system will only heat up once a coffee beverage or steam for hot milk and milk froth is requested.

If Eco mode is turned off, milk froth and hot milk as well as coffee and espresso can be prepared directly one after the other. The steam system remains heated up and uses significantly more energy.

The coffee system will indicate the changed energy consumption.

Lighting

The following options are available:

- Adjust the brightness of the lighting while the system is turned on.
- Adjust the brightness of the lighting while the system is turned off.
- Setting the time the lighting should turn off ("Turn off after").

Adjusting the brightness

First select:

- System turned on
- System turned off

Setting the time the lighting should turn off (Turn off after)

You can select for how long the coffee system lighting should stay on after the system has been turned off.

When the coffee system is switched on, the lighting will remain on for another 10 minutes after the last action. You cannot change this time.

Starting screen

You can select which screen should be displayed when the coffee system is turned on.

- Main menu
- Drinks
- Profiles
- MyMiele

Info (displaying information)

The Info menu option allows you to display the number of portions prepared for each individual drink.

You can also see whether more than 50 portions can be dispensed before the machine needs to be descaled (No. of portions until descaling).

To return to the previous menu:

- Touch "OK".

Locking the coffee system (System lock)

You can lock the coffee system to prevent it being used without your knowledge, for example by children.

Activating and deactivating the system lock

If you have activated the system lock, the timer settings are deactivated. In this case the coffee system will **not** turn on at the specified time.

Settings

Overriding the system lock

While the display shows "Press for 5 seconds to unlock",

- touch the lock symbol for 5 seconds.

As soon as the coffee system is switched off, the system is locked again.

Water hardness

You will find the information on water hardness in the chapter "First steps to use".

Brightness

You can set the brightness of the display in the bar chart.

Volume

You can adjust the volume of the audio signals and keypad tones in the bar chart.

Activating and deactivating the plumbed water supply

The system is designed to be used with a plumbed connection to cold tap water. If the water supply is turned on, the water tank is automatically filled via the cold water line. If the water supply is turned off, you will need to fill the water tank by hand.

Adjusting the dispensers

You can find the information on dispenser adjustment in the chapter "Dispenser adjustment".

Factory default settings

You can reset the settings back to the factory default settings and also delete the MyMiele entries.

Please refer to the "Overview of the setting options" chart for the factory default settings.

The following settings will **not** be reset:

- Language
- Time of day
- Number of drink portions
- Profiles

Showroom program (demo mode)

Do not activate this setting for domestic use.

The coffee system can be presented in "Demo mode" for showrooms or exhibitions. In this mode the system lights up, but no drinks can be prepared or actions carried out.

The coffee system cannot be turned off with the On/Off sensor  when demo mode is activated.

Overview

 The coffee system must be cleaned regularly to prevent a build-up of bacteria.

Recommended frequency	To be cleaned / maintained
Daily (at the end of the day)	Milk container and lid
	Water container
	Waste unit
	Drip tray and no-spill grid
Once a week (more often for heavier soiling)	Main dispenser
	Main dispenser connector
	Clean the milk valve with a cleaning brush
	Interior
	Drip catcher on the inside of the front door
	Brew unit
Once a month	Front of the system (especially important immediately after descaling)
Once a month	Lubricate the cap on the main dispenser connector
When display advises	Milk pipework (using the cleaning agent for milk pipework)
	Brew unit (with cleaning tablets)
	Descale the system
When necessary	Bean container
	Clean clogged milk pipework with the cleaning brush

Some components of the coffee system are dishwasher safe. However, cleaning them frequently in the dishwasher can cause them to become discolored due to food residues (e.g. tomatoes) in the dishwasher, or the surface coating can be damaged.

The following components should be cleaned **only** by hand:

- Main dispenser cover
- Brew unit
- Bean container and lid
- Service cover

Cleaning and care

Danger of burns!

Let the unit cool down before you clean it, especially the water in the drip tray.

Do NOT use a steam cleaner to clean this unit. Doing so will damage the unit.

Never use cleaning products that contain sand, cleaning soda, acids, or chlorides! They will corrode the surface.

To avoid bacteria growth and odors it is important to clean the machine regularly.

The main dispenser connector cap is lubricated with silicone grease. Be careful of your clothing when removing or inserting containers or other components from the inside of the unit.

All surfaces are susceptible to scratching. On glass surfaces, scratches can lead to breakage. All surfaces can become discolored if they are cleaned with unsuitable products.

Make sure to immediately wipe away any **splatters during descaling**.

Glass cleaners may be used to clean the exterior. However **do not** allow them to sit or "puddle", this can cause damage to the surface. **Remove the cleaner promptly.**

To better maintain your appliance avoid the following:

- cleaners containing soda, ammonia, thinners, or chlorides
- cleaners containing descaling agents or lime removers,
- abrasive cleaners,
- stainless steel cleaners,
- caustic (oven) cleaners,
- scouring pads, steel wool, hard brushes,
- eraser sponges,
- metal scrapers.

Wipe any spills from descaling immediately!

Rinsing the system

After a coffee beverage has been prepared, the coffee system rinses itself before turning off. This removes any remaining coffee residue.

You can also rinse the system manually.

- Touch "Main menu" or the ↩ sensor.
- Touch "Maintenance" Ⓞ.
- Touch "Rinse the appliance".

The pipework will now be rinsed. The water used for rinsing will run out of the main dispenser.

Milk pipework

Make sure that the milk pipework is cleaned regularly and thoroughly. Milk contains natural bacteria that will multiply if the pipework is not sufficiently clean. Contamination of the system can be a health risk.

Rinsing the milk pipework manually

Milk residue can clog the milk pipework. If you have prepared a drink with milk, the coffee system will automatically rinse the milk pipework after a few minutes.

You can also rinse the milk pipework manually.

- Touch "Main menu" or the ↩ sensor.
- Touch "Maintenance" Ⓞ.
- Touch "Rinse the appliance".

The milk pipework will be rinsed.

Cleaning and care

Cleaning the milk pipework using the milk line cleaner

Make sure that the milk pipework is cleaned regularly and thoroughly. Milk contains natural bacteria that will multiply if the pipework is not sufficiently clean. Contamination of the system can be a health risk.

The milk pipework must be cleaned about once a week. The coffee system will remind you at the correct time. "Clean the milk pipework in 3 days" is displayed three days before the due date. The remaining number of days until the milk pipework needs to be cleaned will show in the display every time the coffee system is turned on.

- To confirm this message, touch "OK".

When the number of days left is 0, the display will show the message "Clean the milk pipework". The function for preparing drinks with milk is now blocked.

- Touch "OK".

Now you can only prepare espresso, coffee, large coffee and hot water. You can only prepare drinks with milk again once the milk pipework has been cleaned.

The cleaning program cannot be canceled once it has started. The program has to be carried through to the end.

- Touch "Main menu" or the ↩ sensor.
- Touch "Maintenance" Ⓞ.
- Touch "Clean the milk pipework".

The program starts and various messages appear in the display.

- Follow the instructions.

When the display shows "Fill water container with cleaning agent and lukewarm water up to the  symbol and replace", do the following:

Preparing the cleaning solution

The milk system detergent was developed specifically for this coffee machine. It is available from Miele.

To avoid damaging the coffee system, use this cleaning agent only.

- Place one packet of the cleaning agent for milk pipework in the water tank.

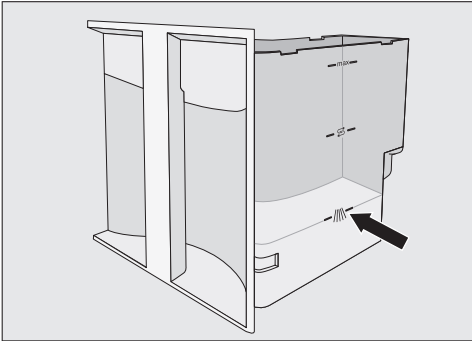

- Fill the water tank with lukewarm water up to the  mark and stir the solution.

Please observe the mixing ratio. It is important that you fill the water tank to the mark. Otherwise, the cleaning process will be incomplete.

- Reinsert the water tank and close the front door.
- Follow the instructions in the display.

When "Fill and replace the water container" is displayed:

- Rinse the water tank carefully with clean water. Make sure that **no** detergent residue is left in the water tank. Fill the water tank with fresh tap water.

The cleaning process is complete when "Program finished" is displayed.

Milk container with lid

Ensure that the neck and lip of the container are kept clean (both when filling and when moving the container). Contamination can cause the system to malfunction.

- The milk container (glass) can be cleaned in the dishwasher or by hand with warm water and liquid dish soap. After cleaning, dry the milk container.

Before placing the milk container lid in the dishwasher:

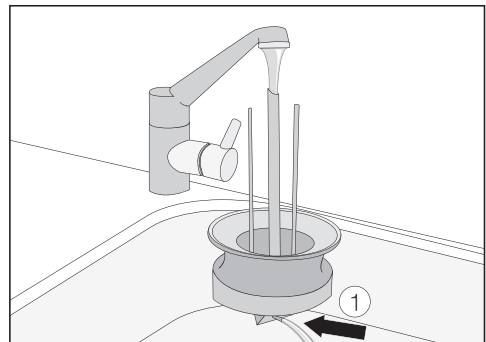

- Rinse the milk pipework in the lid under running water.

If **no** water comes out of the milk pipework ①,

- clean the lid as described in the chapter "Clogged milk pipework – Step 1: Cleaning the milk pipework in the lid of the milk container".

Cleaning and care

Main dispenser

Clean the cover of the main dispenser **by hand only**, using warm water and liquid dishsoap. All other components are dishwasher safe.

The main dispenser must be in the maintenance position for cleaning. Otherwise you will not be able to remove the parts.

If there is a container underneath the main dispenser, remove it so that the main dispenser can move into the maintenance position.

- Touch "Main menu" or the ↶ sensor.
- Touch "Maintenance" Ⓞ.
- Touch "Clean the main dispenser".

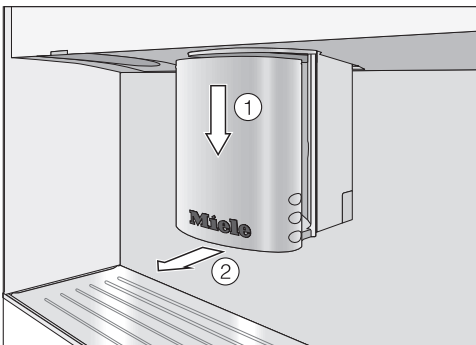

The main dispenser moves into the maintenance position ①.

- Pull the cover forward and off ②.

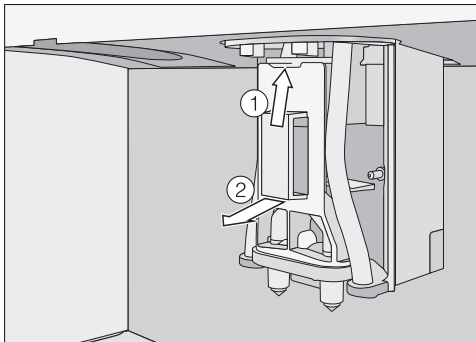

- Push the catch upwards ①, grasp the dispensing unit by the handle and pull it out towards the front ②.

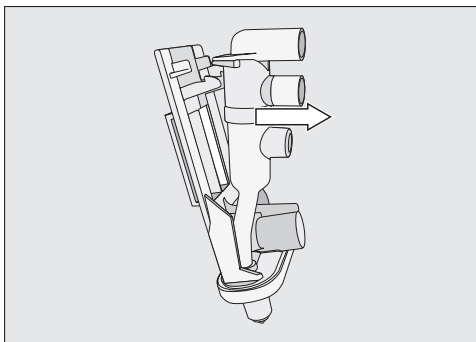

- Hold the magnets at the side and pull forwards to release the unit.

Cleaning and care

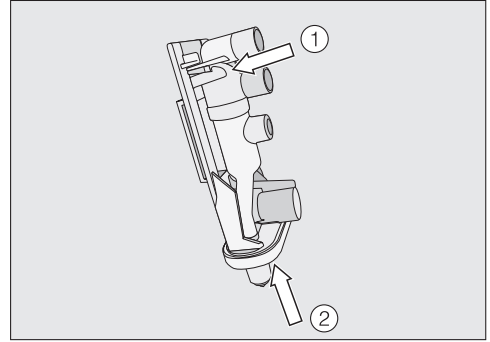
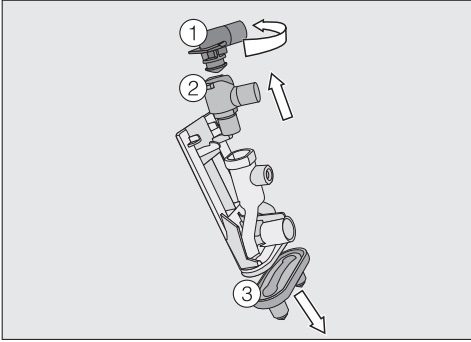

- Turn the top connecting piece ① and pull it up and off. Then pull the bottom connecting piece ② up and off.
- Pull off the dispensing nozzles ③.

Do not remove the Y-piece.

- Thoroughly clean all components.

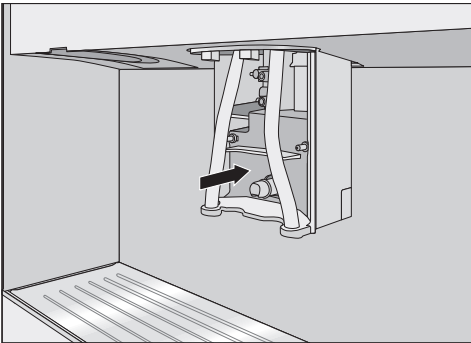

- Clean the surface of the main dispenser with a damp sponge.

- Now reassemble the dispensing unit in the reverse order. Make sure that the upper connecting piece ① clicks into place. Push the dispensing nozzles ② firmly onto the dispensing unit.
- Reinsert the dispensing unit.
- Replace the cover.

Cleaning and care

Cleaning the milk valve

You should clean the milk valve once a week to ensure good quality milk froth.

- Touch "Main menu" or the ↩ sensor.
- Touch "Maintenance" Ⓞ.
- Touch "Clean the main dispenser".

The main dispenser and the milk valve move into the maintenance position.

Important! Before you confirm "Leave maintenance position" with "OK", you **must** remove the cleaning brush. Otherwise, the coffee system will be damaged.

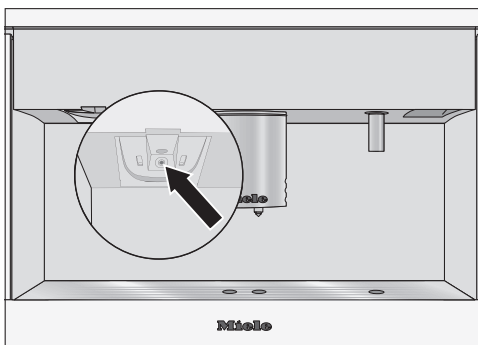

- Insert the brush into the milk valve. Move the brush back and forth.
- Touch "OK".

The milk valve will move into the standard position and the milk pipework is rinsed.

Sensor cover

The sensor cover for the cup protection shut-off is located under the main dispenser. If the automatic dispenser adjustment sensors do not clearly recognize a container, the cup protection shut-off stops the main dispenser.

Clean the sensor cover **by hand only** as necessary using warm water and liquid dish soap.

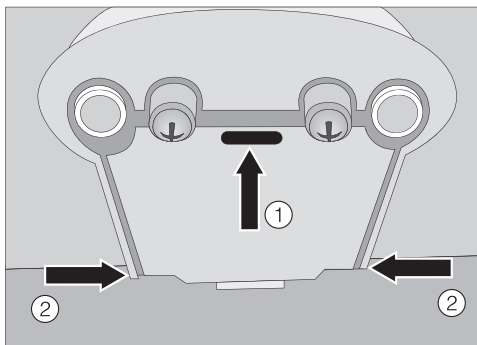

- To remove, press and hold the sensor cover between the dispenser nozzles ①. Then press the main dispenser in from the sides at the back ②.

This releases the sensor cover.

- To replace, insert both hooks at the back and press the sensor cover upwards.

Water tank

Change the water every day to prevent a build-up of bacteria.

Make sure that the valve, the underside of the water tank and the surface that the water tank sits on are clean. Otherwise the water tank will not sit correctly.

- The water tank can be cleaned in the dishwasher or by hand using warm water and liquid dish soap. After cleaning, dry the water tank.

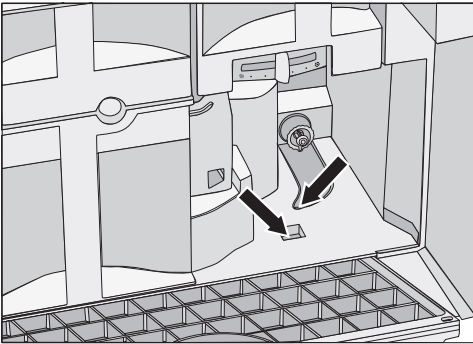

- Carefully clean and dry the surface that the water container sits on, particularly the slots.

Waste unit

After a certain time, the coffee system displays a message indicating that the waste unit needs to be emptied. At this point the container must be cleaned.

However, it is best to clean the waste container **daily**. Coffee grounds can become moldy.

Typically there will also be some water in the waste container, left over from the brewing and rinsing processes.

- Wash the waste container in the dishwasher or by hand with warm water and liquid dish soap, then dry.
- Also thoroughly clean the now accessible areas inside the appliance.

Cleaning and care

Drip tray

Clean the drip tray **daily** to prevent odors and mold.

The coffee system displays a message when the drip tray is full and needs to be emptied. At this point the drip tray must be emptied.

Risk of burns!

If the coffee system has just been rinsed, wait a while before removing the drip tray. Rinse water runs out of the dispensers.

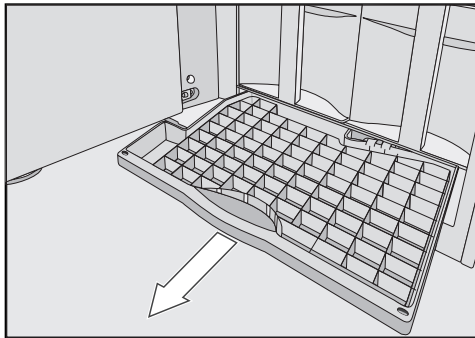

- Open the front door and carefully remove the drip tray.

The grid in the drip tray helps keep the water in place while you move the full drip tray.

- Wash the drip tray by hand only. The grid can be washed in the dishwasher, or by hand with warm water and liquid dish soap. Dry thoroughly.

Make sure that the metal discs (contacts) on the drip tray are cleaned and dried properly. If they are dirty or damp, the discs will not be able to detect that the drip tray is in place or that it is full.

- Clean the space under the drip tray.
- Push the drip tray back into the coffee system.

Make sure the drip tray is pushed in as far as it will go.

Drip tray cover

- Remove the drip tray cover.
- The drip tray cover can be cleaned in the dishwasher or by hand using warm water and liquid dish soap.
- Dry the drip tray cover thoroughly.

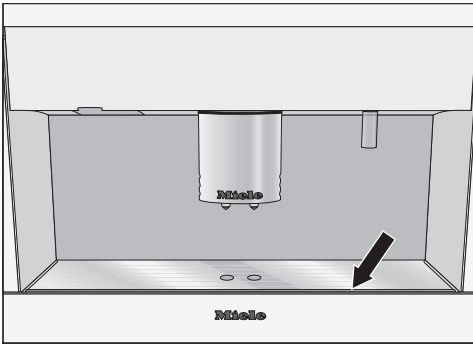

- Replace the cover onto the drip tray. Make sure that the front of the cover is flush with the drip tray.

Bean container

- Pull the bean container out of the appliance and pull the lid toward the back and off.
- Clean the bean container and its lid **by hand** using warm water and liquid dish soap. Dry both components.
- Slide the lid back on, then slide the bean container back into the appliance.

Main dispenser connector

A connecting piece between the brew unit and the main dispenser is located on the inside of the front.

- Clean this connector on a regular basis with a damp cloth, but take care not to remove the lubricant from the cap.

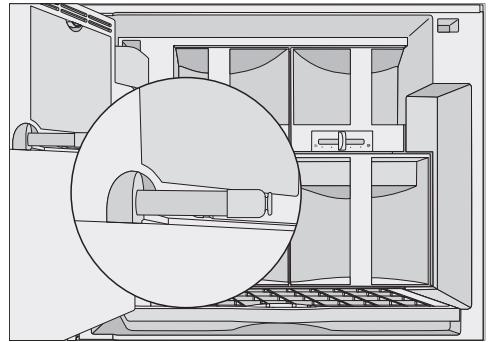

- Once a month, lubricate the cap with the silicone grease provided.

Cleaning and care

Interior and front door

- Clean the interior and the front door with warm water and liquid dish soap once all removable parts have been removed.

Tip: Use a vacuum cleaner to remove dry coffee grounds.

In the lower part of the inside of the front door there is a drip catcher.

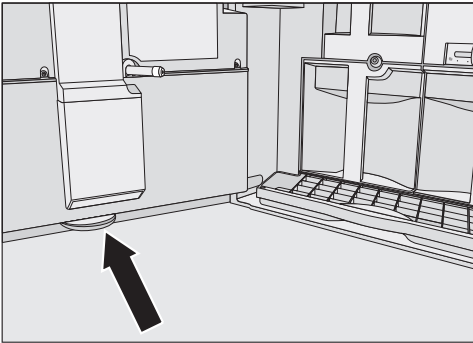

- Remove this cup and clean it in the dishwasher or by hand using warm water and liquid dish soap.

Remember to reinsert the drip catcher.

Brew unit

Clean the brew unit **by hand only** using warm water. **Do not use soap.**

The moving parts of the brew unit are lubricated. Detergents will damage the brew unit.

Clean the brew unit once a week.

Removing the brew unit and rinse it by hand

The brew unit can be removed for cleaning.

- Open the front door.
- Remove the water container, the waste unit, and the ground coffee chute lid.

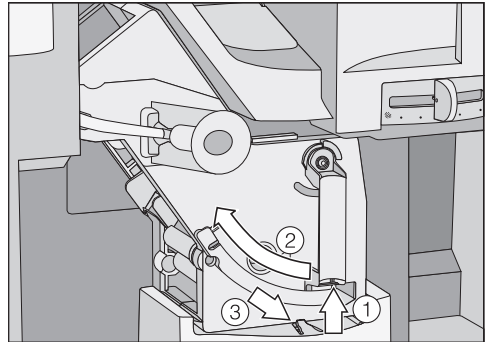

- Press the button at the bottom of the brew unit handle ① while turning the handle to the left ②.
- Press the brew unit catch ③ downward, and carefully pull the brew unit out of the machine.

If you cannot remove the brew unit or can only do so with difficulty, the brew unit is not in the correct position (see "Frequently asked questions").

When the brew unit has been pulled out, do **not** alter the position of the brew unit handle. This would shift the brew unit and it would not fit back into the coffee system.

- Clean the brew unit **by hand under running hot water**. Do not use soap.

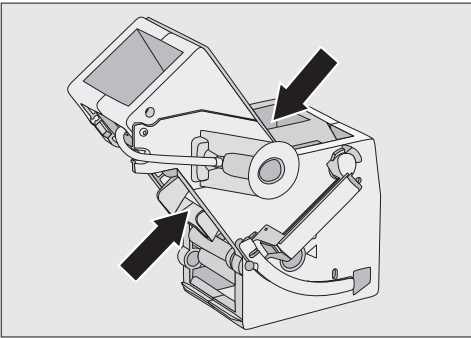

To replace the brew unit, repeat the previous steps in the reverse order:

- Push the brew unit back into the coffee system, making sure it is straight.

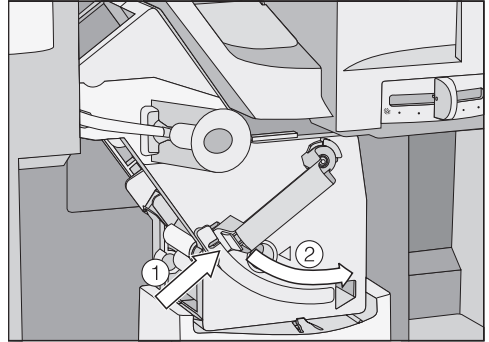

- Push the button on the bottom of the brew unit handle ① while turning the handle to the right ②.
- Close the door.

- Rub any coffee residue from the filters. One filter is located inside the funnel, the other to the left of the funnel.
- Dry the funnel to prevent ground coffee from sticking to it the next time coffee is prepared.
- Clean the inside of the coffee system. Use your vacuum cleaner to remove dry coffee grounds.

Cleaning and care

Degreasing the brew unit

Depending on the natural oil content of the coffee used, the brew unit can become blocked quite quickly. Use the supplied cleaning tablets to clean the brew unit.

These cleaning tablets were specially formulated for use in the coffee system. They are available from Miele.

After 200 portions, the display will show the message "Degrease brew unit". This message will be displayed until the brew unit has been degreased.

Degrease the brew unit regularly. This ensures that the coffee system continues to dispense aromatic coffee and operates problem-free.

The cleaning program cannot be stopped once it has started. The program has to be carried through to the end.

- Touch the On/Off sensor ① to turn the coffee system on.
- Touch "Main menu" or the ↶ sensor.
- Touch "Maintenance" ②.
- Touch "Degrease brew unit".
- Follow the instructions in the display.

When the display prompts you to "Place a cleaning tablet in the ground coffee chute and close the chute":

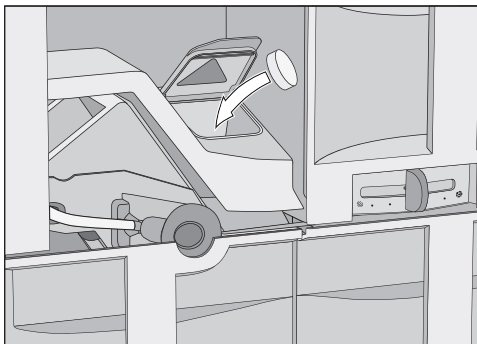

- Remove the ground coffee chute cover and open the chute lid.
- Drop the cleaning tablet into the chute.
- Close the lid, put the cover back on, and close the door.
- Follow the instructions in the display.

When "Program finished" is displayed:

- Touch "OK".

The brew unit is now cleaned.

Exterior

The surfaces can become discolored or otherwise altered if soiling is not cleaned promptly. Remove any soiling immediately.

Make sure no water can penetrate the display!

All external surfaces are susceptible to scratching. On glass surfaces, scratches can lead to breakage. All surfaces can become discolored if they are cleaned with unsuitable products.

Make sure to immediately wipe away any **spills during descaling!**

- Touch the On/Off sensor ① to turn the coffee system off.
- Use a clean, soft sponge with warm water and liquid dish soap to clean the housing. Dry all parts with a soft cloth.

Tip: You can also clean the exterior using the Miele micro fiber cloth.

Descaling

Limescale builds up in the coffee system during use. The limescale buildup in the system depends on the hardness of your local water supply. Limescale must be removed regularly.

The system guides you through the descaling process. Various instructions appear in the display, e.g. you are prompted to empty the drip tray or fill the water tank.

Descaling is **absolutely necessary** and takes approximately 20 minutes.

During the descaling program, water containing descaling agent runs out of the main dispenser and the hot water dispenser. This is followed by a working-in period before a little more water with descaling agent is dispensed, etc.

The coffee system will remind you via the display when the descaling program needs to be carried out. The following message will appear in the display: "No. of uses until appliance needs descaling: 50". The remaining number of portions that can be made before descaling will show in the display after each beverage is made.

- Touch "OK" to confirm this message.

When the number of remaining drinks is 0, the coffee system will lock. The display will read, "Please descale".

You can turn the coffee system off if you do not want to run the descaling program at this time. However, no more drinks can be prepared until the descaling program has been completed.

Descaling after being prompted by the display

The descaling program cannot be canceled once it has started. The program has to be carried through to the end.

- Touch "OK" to start descaling immediately.

The descaling process starts and various messages appear in the display.

- Follow the instructions.

When the display shows "Fill water container with lukewarm water and descaling solution up to the S symbol and insert", proceed as follows:

Preparing the descaling solution

The descaling tablets provided were specially formulated for use with this coffee system. Additional descaling tablets are available from Miele.

You need **two** descaling tablets for the descaling process.

Only use Miele descaling tablets. Other types of descaling agents can damage the system and affect the taste.

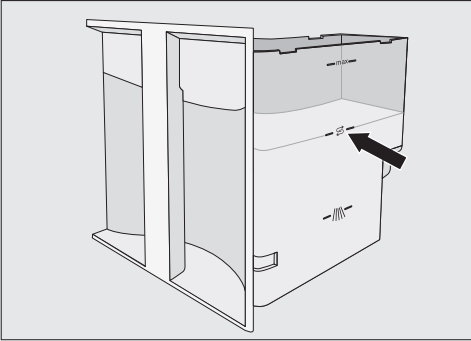

- Fill the water tank to the  mark with lukewarm water.
- Add **two** descaling tablets to the water.

Please observe the mixing ratio for the descaling tablets. It is important that you fill the water tank to the mark. Too little water can cause the descaling program to stop prematurely.

- Reinsert the water tank and close the door.
- Follow the instructions in the display.

When the display shows, "Fill the water container with fresh tap water up to the descaling mark":

- Rinse the water tank carefully with clean water. Make sure that no descaling agent is left in the water tank. Fill clean tap water up to the  mark.
Also empty the waste container.

The descaling process is complete when "Program finished" is displayed.

- Touch "OK".

The descaling program is now complete and drinks can be prepared again.

When descaling the system, be sure to wipe off any splatters of descaling agent immediately! These could damage the surfaces.

After descaling the system, carefully clean the water tank and the drip tray to remove all traces of descaling agent.

Descaling before being prompted

The descaling program cannot be canceled once it has started. The program has to be carried through to the end.

- Touch "Main menu" or the "Back" sensor.
- Touch "Maintenance" .
- Touch "Descal unit".

The descaling process will start.

Frequently asked questions

 Repairs to electrical appliances should only be carried out by a suitably qualified person in accordance with local and national safety regulations. Repairs and other work by unqualified persons could be dangerous. The manufacturer cannot be held responsible for unauthorized work.

Display messages

- To address the "fault", follow the instructions on the display.
- If the fault message still appears on the display, contact Miele Technical Service.

Fault	Possible cause and solution
Fault 1 - 4 80 - 83	There is an internal malfunction. <ul style="list-style-type: none">■ Touch the On/Off sensor ① to turn off the coffee system. Wait about one hour and then turn the system back on.
Fault 74, 77 Fault 225, 226 Fault 235, 236	There is an internal malfunction. <ul style="list-style-type: none">■ Touch the On/Off sensor ① to turn off the coffee system. Wait about 2 minutes and then turn the system back on.

Frequently asked questions

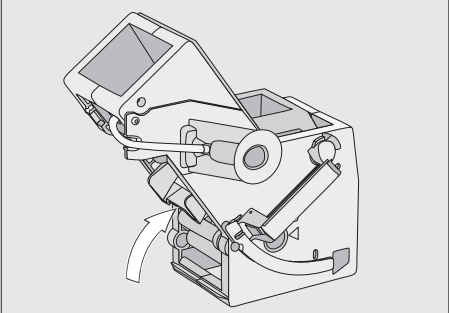
Fault	Possible cause and solution
Fault 73 or "Check brew unit"	<p>The brew unit cannot reset to the correct position or it is clogged and the ground coffee cannot be processed.</p> <ul style="list-style-type: none">■ See if you can remove the brew unit (see "Cleaning and care – Brew unit").■ If you can remove the brew unit, clean it (see "Cleaning and care – Brew unit").  <ul style="list-style-type: none">■ Push the coffee ejector of the brew unit into the standard position (see illustration).■ Reinsert the waste unit and the water container. Do not insert the brew unit. Close the door and turn on the coffee system using the On/Off sensor ①. <p>The brew unit motor will automatically move to the correct position.</p> <ul style="list-style-type: none">■ When the message "Insert brew unit" is displayed, open the door and reinsert all the parts into the coffee system. Close the front door. <p>If you cannot remove the brew unit:</p> <ul style="list-style-type: none">■ Touch the On/Off sensor ① to turn off the coffee system. Wait about 2 minutes and then turn the system back on.
Fault 227 - 230, Fault 233	<p>The automatic dispenser adjustment is malfunctioning.</p> <ul style="list-style-type: none">■ To confirm the message, press OK. <p>The automatic dispenser adjustment will be deactivated during beverage preparation as long as the system remains turned on. You can still make beverages.</p>

Frequently asked questions

Fault	Possible cause and solution
Fault 234	<p>The cup protection shut-off has been triggered three times since the coffee system was turned on. The cups or glasses being used are not clearly recognized by the automatic dispenser adjustment.</p> <ul style="list-style-type: none"> ■ Use only cups or glasses that can be recognized by the automatic dispenser adjustment. <p>The automatic dispenser adjustment is malfunctioning.</p> <ul style="list-style-type: none"> ■ Touch the On/Off sensor ① to turn off the coffee system. Wait about 2 minutes and then turn the system back on.
"Too much ground coffee"	<p>There is too much ground coffee in the ground coffee chute. If more than one level scoop is put into the ground coffee chute the brew unit cannot process it. The ground coffee will be directed into the waste unit, and an fault message will be displayed.</p> <ul style="list-style-type: none"> ■ Touch the On/Off sensor ① to turn off the coffee system. ■ Remove the brew unit and clean it (see "Cleaning and care – Brew unit"). ■ Remove all ground coffee from the interior of the coffee system, for example with a vacuum cleaner. ■ Use the supplied coffee scoop to measure out the ground coffee. Scoop only one serving of ground coffee into the ground coffee chute.
"Check water intake"	<p>The plumbed water intake is malfunctioning.</p> <ul style="list-style-type: none"> ■ Check for kinks in the water intake hose and make sure that the water shut-off valve is open all the way. ■ Remove the water container and empty it. ■ Push the water container back into the unit until it clicks into place.

Frequently asked questions

Fault	Possible cause and solution
"Push the water container in until it engages"	The water container is not sitting properly in the appliance. ■ Take the water container out, then put it back into the appliance.
	This fault message will also appear if the water container is not correctly filled and inserted during descaling. ■ Fill it to the descaling mark  and restart the descaling process.
	The plumbed water intake is malfunctioning. ■ Check for kinks in the water intake hose and make sure that the water supply is open all the way.

Frequently asked questions

Unusual behavior of the coffee system

Problem	Possible cause and solution
The lighting does not come on when the coffee system is turned on.	The lighting has been turned off. ■ Turn on the lighting (see "Settings – Lighting").
	The lighting is defective. ■ Contact Technical Service.
The display remains dark when the coffee system is turned on using the On/Off sensor ①.	The On/Off sensor ① was not touched long enough. ■ Touch the depression in the On/Off sensor ① for at least 3 seconds.
	The plug is not properly plugged into the electrical outlet. ■ Insert the plug into the electrical outlet.
	The circuit breaker has tripped due to a problem with the coffee system, the electricity supply or another device. ■ Unplug the coffee system. ■ Contact a qualified electrician or Miele Technical Service for assistance.
The coffee system turns off suddenly.	The programmed turn-off time has been reached. ■ If desired, set a new turn-off time (see "Settings – Timers").
	The plug is not properly plugged into the electrical outlet. ■ Insert the plug into the electrical outlet.
The coffee system is on. The lighting turns off suddenly.	If more than 10 minutes have passed since the coffee system was last used, the lighting automatically turns off.
The sensor buttons do not respond. The coffee system can no longer be operated.	There is an internal malfunction. ■ Open the front door of the coffee system.
	The current process is stopped. ■ Unplug the coffee system.

Frequently asked questions

Problem	Possible cause and solution
<p>The coffee system does not turn on at the programmed time even though "Turn on at" is activated.</p>	<p>System lock is activated.</p> <ul style="list-style-type: none"> ■ Deactivate system lock (see "Settings – System lock").
	<p>No days of the week have been selected.</p> <ul style="list-style-type: none"> ■ Check the timer settings and adjust if necessary (see "Settings – Timers").
	<p>The coffee system was not used after being automatically turned on three times in a row (see "Settings – Timers").</p> <ul style="list-style-type: none"> ■ Turn the system on and prepare a drink.
<p>The displayed messages are difficult to read.</p>	<p>The brightness of the display is set too low.</p> <ul style="list-style-type: none"> ■ Adjust this setting (see "Settings – Display brightness").
<p>After the coffee system has been turned on, the message "Fill and insert water tank" appears although the tank is full and inserted. The system does not rinse.</p>	<p>There is limescale build-up in the coffee system.</p> <ul style="list-style-type: none"> ■ Touch the On/Off sensor ① to turn off the coffee system. Wait for approx. 1 hour. ■ Turn the system on again. As soon as "Preheating phase" appears, touch "Maintenance" (bottom right) and select "Descale unit". ■ Descale the coffee system. You may need to repeat the descaling process.
<p>The milk pipework is being rinsed but no rinse water comes out of the main dispenser. The message "Fill and insert water tank" is displayed.</p>	<p>The milk pipework or the air intake hose is clogged.</p> <ul style="list-style-type: none"> ■ Follow the instructions in chapter "Cleaning clogged milk pipework".
<p>No milk or milk froth comes out of the main dispenser.</p>	<p>The milk pipework or the air intake hose is clogged.</p> <ul style="list-style-type: none"> ■ Follow the instructions in chapter "Cleaning clogged milk pipework".

Frequently asked questions

Problem	Possible cause and solution
The display shows the message "Fill and insert milk container" although the milk container is full and in place.	<p>The milk container lid may be soiled, causing the sensors to malfunction.</p> <ul style="list-style-type: none"> ■ Thoroughly clean the lid and milk container (see "Cleaning clogged milk pipework").
"Empty drip tray" appears in the display even though the drip tray is empty.	<p>The drip tray is not inserted correctly.</p> <ul style="list-style-type: none"> ■ Slide the drip tray all the way into the unit.
	<p>The drip tray's sensors are not working properly.</p> <ul style="list-style-type: none"> ■ Touch the On/Off sensor ① to turn off the coffee system.
	<p>The metal contacts are dirty.</p> <ul style="list-style-type: none"> ■ Clean and dry the contacts thoroughly (see "Cleaning and care – Drip tray").
The front door cannot be closed.	<p>The containers are not fully inserted.</p> <ul style="list-style-type: none"> ■ Check the containers.
The front door cannot be closed.	<p>The door hinges are not aligned correctly.</p> <ul style="list-style-type: none"> ■ Adjust the door hinges (see "Installation – Adjusting the door hinges").
The coffee system suddenly stopped preparing a beverage.	<p>If the water tank is emptied during beverage preparation, the display will show the message "Continue preparation? yes / no" after the water tank has been refilled and inserted. If you do not confirm this message with "yes" within 5 minutes, the system will stop preparing the beverage.</p>
	<p>The plumbed water intake is malfunctioning.</p> <ul style="list-style-type: none"> ■ Check for kinks in the water intake hose and make sure that the water shut-off valve is open all the way.
	<p>The water tank ran empty during beverage preparation, but "Plumbed water connection - on" is selected and the coffee system is not connected to a plumbed water supply.</p> <ul style="list-style-type: none"> ■ Check the plumbed water supply settings (see "Settings – Plumbed water connection").

Frequently asked questions

Problem	Possible cause and solution
<p>"Please wait" or "Preheating phase" is always on. No beverages can be prepared.</p>	<p>It is possible that "Plumbed water connection - on" is selected but the coffee system is not connected to a plumbed water supply.</p> <ul style="list-style-type: none"> ■ Fill the water tank. ■ Then check the plumbed water supply settings (see "Settings – Plumbed water connection").
<p>The cup or glass being used is repeatedly not recognized by the automatic dispenser adjustment. The main dispenser moves to the rim of the cup and triggers the cup protection shut-off.</p>	<ul style="list-style-type: none"> ■ Use only cups or glasses which can be recognized by the automatic dispenser adjustment. <p>The automatic dispenser adjustment is malfunctioning.</p> <ul style="list-style-type: none"> ■ Touch the On/Off sensor ① to turn off the coffee system. Wait about 2 minutes and then turn the system back on. ■ Use another cup or glass and make a drink. ■ If the cup protection shut-off is triggered again or the main dispenser moves to the rim of the cup or glass again, contact Miele Technical Service.
<p>The cup protection shut-off is malfunctioning. The main dispenser moves to the rim of the cleaning container, jamming it in.</p>	<p>If the cleaning container is very close to or touching the back panel, the automatic dispenser adjustment will not detect it properly.</p> <ul style="list-style-type: none"> ■ Move the cleaning container further forward.

Frequently asked questions

Unsatisfactory results

Problem	Possible cause and solution
The consistency of the milk froth is unsatisfactory.	The milk temperature is too high. Good milk froth can only be prepared with cold milk (< 55°F/13°C). ■ Check the milk temperature in the milk container.
	The milk pipework or the air intake hose is clogged. ■ Follow the instructions in chapter "Cleaning clogged milk pipework".
The grinding of the coffee beans sounds louder than usual.	The coffee bean container has run empty during the grinding process. ■ Fill the coffee bean container with fresh beans.
	There might be stones mixed in with the coffee beans. ■ Turn the coffee system off immediately. Contact Miele Technical Service.
Espresso or coffee flows into the cup too quickly.	The grind level is too coarse. ■ Set the grinder control to a finer setting (see "Adjusting the grinder setting").
Espresso or coffee flows into the cup too slowly.	The grind level is too fine. ■ Set the grinder control to a coarser setting (see "Adjusting the grinder setting").
The coffee or espresso is not hot enough.	The cup has not been pre-heated.
	The brewing temperature is set too low. ■ Set a higher brewing temperature (see "Brewing temperature").
	The brew unit filters are blocked. ■ Remove the brew unit and clean it by hand (see "Brew unit"). ■ Degrease the brew unit (see "Brew unit").

Frequently asked questions

Problem	Possible cause and solution
There is no proper crema on the coffee or espresso.	The grind level is too coarse or too fine. ■ Set the grinder control to a coarser or finer setting (see "Adjusting the grinder setting").
	The brewing temperature is too high for the type of coffee being used. ■ Set a lower brewing temperature (see "Brewing temperature").
	The coffee beans are no longer fresh. ■ Add fresh beans to the coffee bean container.

Cleaning clogged milk pipework

If the **quality of the milk froth** is unsatisfactory, the air intake hose may be clogged. Follow the instructions in "Step 2: Cleaning the air intake hose and angled section in the door."

If **no milk** comes out of the main dispenser, only **steam**, please follow the instructions in Steps 1 to 3.

First check if the milk in the milk container has spoiled. This can clog the milk pipework.

To clean the clogged milk pipework, take a step-by-step approach. Afterwards, check if the preparation and quality of the milk and/or milk froth are satisfactory.

If the preparation and quality of the milk and/or milk froth are still not satisfactory, do **not** make any drinks and repeat the steps described.

Step 1: Cleaning the milk pipework in the lid of the milk container

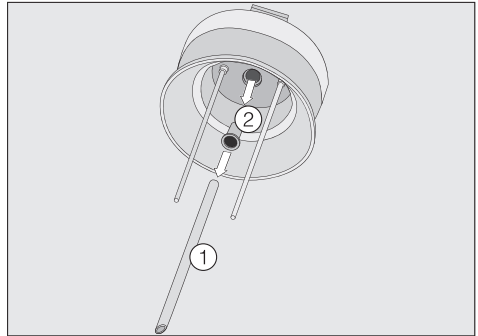

- Pull the milk intake pipe ① out of the milk container lid. Make sure you also remove the seal ②.
- Clean both under running water. Insert the supplied cleaning brush into the stainless steel pipe and move it back and forth until all milk residue has been removed.

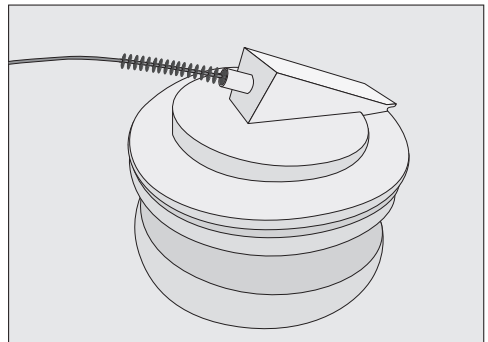

- Use the cleaning brush to clean the milk pipework in the lid as well.

Cleaning clogged milk pipework

To reassemble the lid:

- **First** put the seal in the lid. Then insert the milk intake pipe into the seal.
Make sure not to slide the beveled end of the milk intake hose into the seal.

Step 2: Cleaning the air intake hose and angled section in the front door

Do not use a needle or similar sharp item. They can damage the parts.

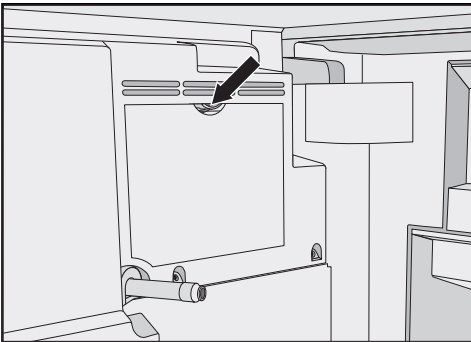

- Open the service cover on the back of the front door.

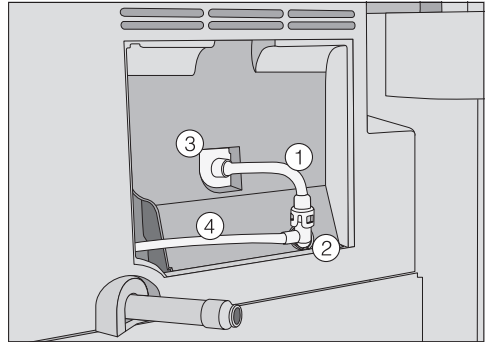

- First detach the air intake hose ① from the opening ③. Then pull off the angled section ②.
- Pull both hoses out of the angled section.
- Clean the air intake hose ① using the supplied cleaning brush. "Blowing through" can also dislodge any blockages.
- Clean the opening for the air intake hose ③ in the front door.
- Clean the angled section ② under running water. If necessary, replace it with the supplied spare part.
- Insert the brush into the milk hose ④. Move the brush back and forth until all milk residue has been removed.

Cleaning clogged milk pipework

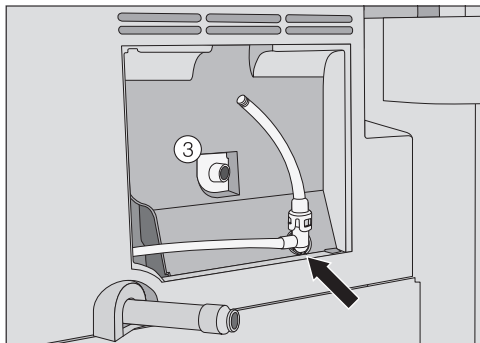

- Slide the hoses back onto the angled section and reinsert it.
- Reinsert the air intake hose into the opening ③.

Step 3: Cleaning the milk valve and the milk pipework in the main dispenser

- Touch "Main menu" or the "Back" sensor.
- Touch "Maintenance" ④.
- Touch "Clean the main dispenser".

The main dispenser and the milk valve will move into the maintenance position.

Important! Before you confirm "Leave maintenance position" with "OK", you **must** remove the cleaning brush. Otherwise, the coffee system will be damaged.

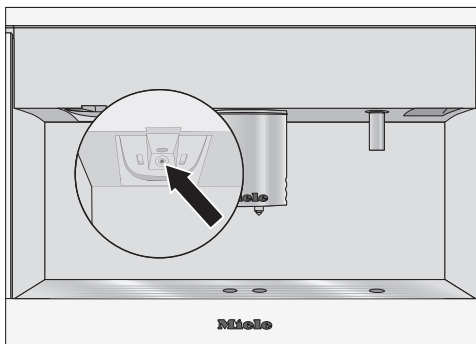

- Insert the brush into the milk valve. Move the brush back and forth.
- Remove and disassemble the dispensing unit as described in "Cleaning and care – Main dispenser".
- Rinse all parts carefully under running water.

Use the cleaning brush to clean all parts **carefully**. Do not use a needle or suchlike in order to avoid piercing the silicone parts.

- Reassemble the dispensing unit and reinsert it into the main dispenser.
- Replace the cover.
- Touch "OK".

The milk valve will move into the standard position and the milk pipework is rinsed.

In the event of a fault which you cannot easily fix yourself, please contact the Miele Technical Service Department at the contact information on the back of this booklet.

When contacting the Technical Service Department, please quote the model and serial number of your appliance given on the data plate inside the appliance.

MieleCare

(USA only)

MieleCare, our Extended Service Contract program, gives you the assurance of knowing that your appliance investment is covered by 5 years of worry free ownership.

MieleCare is the only Extended Service Contract in the industry that guarantees repairs by a Miele Authorized Service Provider using genuine Miele parts. Only genuine Miele parts installed by factory trained professionals can guarantee the safety, reliability, and longevity of your Miele appliance.

Please note that unless expressly approved in writing by Miele's Service department, Extended Service Contracts offered by other providers for Miele products will not be recognized by Miele. Our goal is to prevent unauthorized (and untrained) service personnel from working on your Miele products, possibly doing further damage to them, you and/or your home.

To learn more about **MieleCare** Extended Service Contracts, please contact your appliance dealer or visit us online at:

<http://mieleusa.com/mielecare>

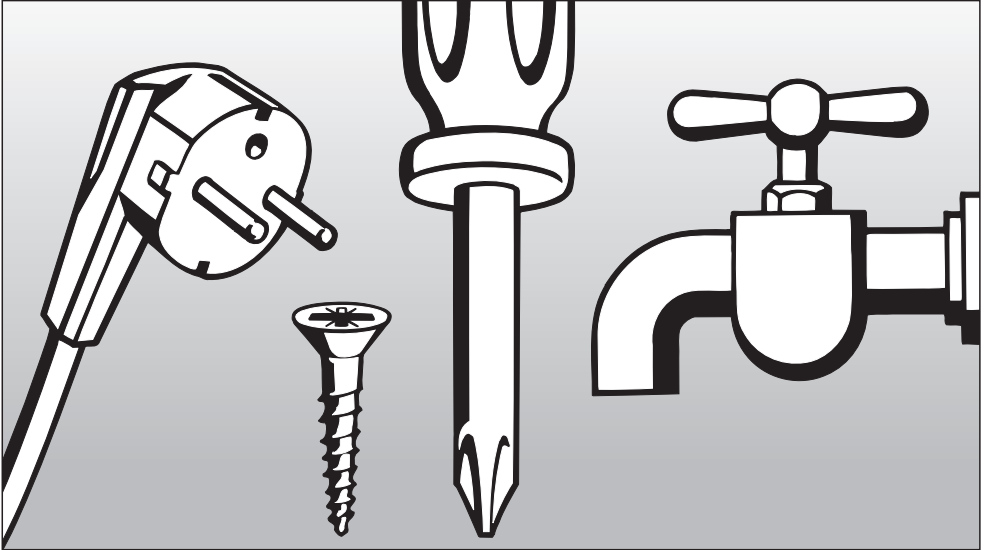

Installation instructions

Information is subject to change. Please refer to our website to obtain the most current product specification, technical & warranty information.

Leave these instructions with the appliance for the consumer/user.

Information is subject to change. Please refer to our website to obtain the most current product specification, technical & warranty information.

Disposal of packing material

The cardboard box and packing materials protect the appliance during shipping. They have been designed to be biodegradable and recyclable. Please recycle.

Ensure that any plastic wrappings, bags, etc. are disposed of safely and kept out of the reach of children.
Danger of suffocation!

Disposal of an old appliance

Old appliances may contain materials that can be recycled. Please contact your local recycling authority about the possibility of recycling these materials.

Ensure that the appliance presents no danger to children while being stored for disposal. Before discarding an old appliance, unplug it from the outlet, cut off its power cord and remove any doors to prevent hazards.

Plumbing

The machine must be connected to the water supply in accordance with local and national regulations.

Disconnect the machine from the electrical supply before connecting it to the water supply.

Turn off the water supply before connecting the coffee machine to the plumbing.

- To ensure the best coffee quality, the maximum length of the tubing or copper pipe should not exceed 4 ft. 11" (1.5 m). If too much water remains in the tubing the coffee quality could be affected.

Make sure that the shut-off valve is accessible after the unit has been installed.

Parts must only be replaced with original Miele spare parts, available from Miele.

- All units and systems used to deliver the water to the coffee system must conform with the requirements of the respective country.
- Only connect the machine to the cold water supply.
- The machine can be connected without a non-return valve.
- The on-site water line must have a water shut-off valve to turn the water off if needed. If not present, have a water valve installed by a licensed plumber.
- The water faucet must be accessible after installation.
- Water pressure on-site:
Minimum: 14.5 psi
Maximum: 145 psi, if higher, install a pressure reduction valve.
- Suitable 1/4" tubing or copper piping must be supplied for plumbing.

Installing the stainless steel tubing in the unit

- Remove the water connection cover at the lower rear side of the coffee machine.
- Take the **angled** side of the stainless steel tube and check whether the sealing ring is in place. If necessary, insert it.
- Place the union nut of the stainless steel tube onto the screw thread.
- Make sure the fittings are tight.

Connection to the water supply

Disconnect the machine from the electrical supply before connecting it to the water supply.

- Remove the water connection cover at the lower rear side of the coffee machine.
- Check whether the sealing ring is in place. If necessary, insert it.

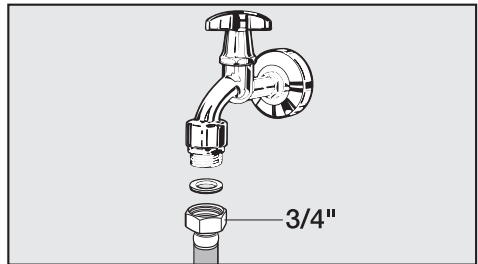

- Screw the supplied brass compression fitting, with the $\frac{3}{4}$ " end, tightly onto the water connector of the coffee machine. (Tighten the compression fitting by hand, do not use a tool.) The fitting includes an opening for standard $\frac{1}{4}$ " piping.
- Connect the compression fitting to the water supply.
- Slowly open the shut-off valve to the water supply and check for leaks. If necessary, check whether the sealing ring and fittings are tight.

You can now continue with the installation of the unit (see "Installation").

Lead free certificate



This product is tested and certified by the WQA against ORD0902 for California "lead free" compliance.

Miele & Cie KG
Carl-Miele-Straße 29
D-3332 Gütersloh

Make sure that the power to the machine is OFF before installing or performing maintenance or repairs.

All electrical work should be performed by a qualified electrician in strict accordance with national and local safety regulations. Installation, repairs and other work by unqualified persons could be dangerous.

WARNING:
THIS APPLIANCE MUST BE GROUNDED

Important

The coffee system comes equipped with a 6 ft (1.8 m) power cord with a NEMA 5-15P molded plug for connection to a 120 V, 15 A, 60 Hz power supply.

Verify that the voltage, load and circuit rating information found on the data plate match the household electrical supply before installing the coffee system.

Do not connect the appliance to a power inverter or directly to power produced outside of the normal electrical grid (i.e. direct solar or wind power source).

Direct connection to such power sources can cause power surges and tripped breakers when the appliance is turned on, and could damage the appliance.

Do not connect the appliance to energy saving plugs or outlets. The reduction of power to the appliance caused by these devices will cause the appliance to run hot and may damage it and/or shorten its usable life.

If there is any question concerning the electrical connection of this appliance to your power supply, please consult a licensed electrician or contact Miele's Technical Service Department. See back page for contact information.

Installation

Installation and combination options

The system is designed to be built into cabinetry.

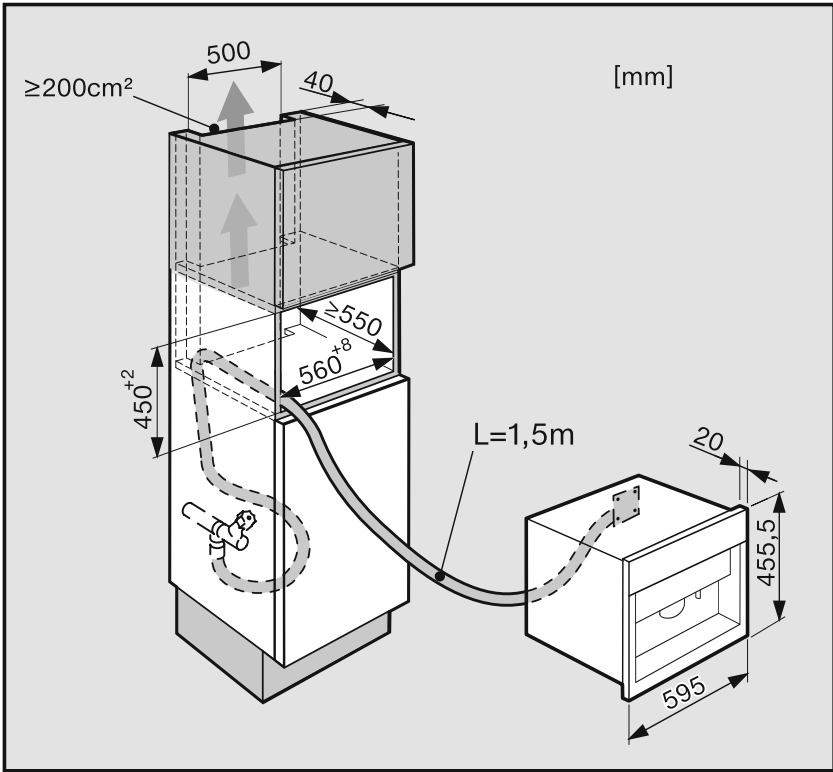

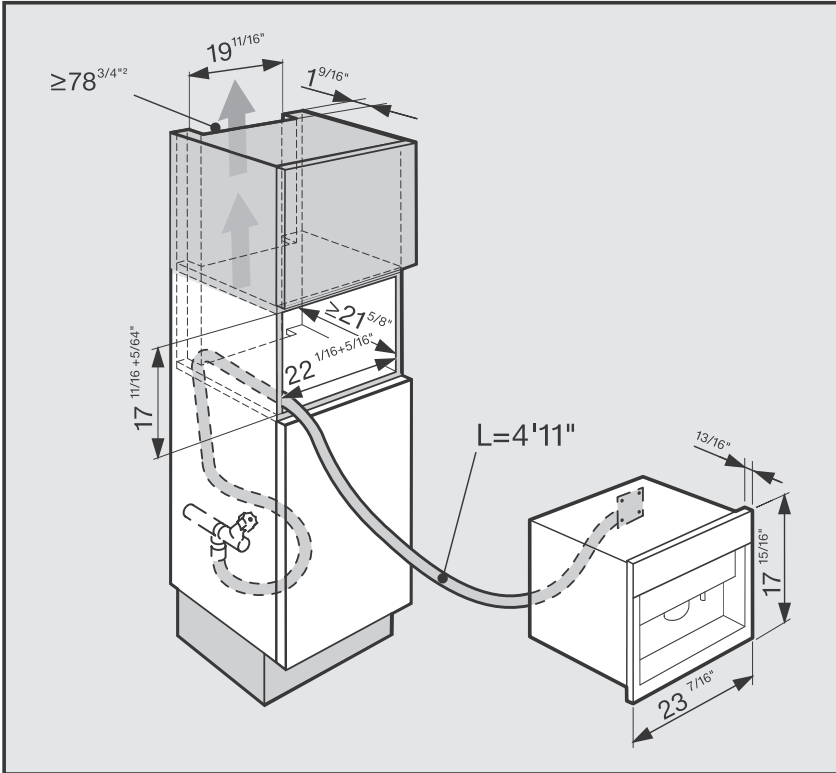

It is also possible to combine it with other built-in Miele appliances. If the coffee system is to be built in above another appliance, there must be a full-width, closed shelf between them (exception: installation with a built-in warming drawer).

Installation

Ventilation

When installing the coffee system, make sure that it is sufficiently ventilated at the back so that steam and hot air can escape.

The ventilation openings in the surrounding cabinets and the space below the ceiling must be at least $78 \frac{3}{4}''^2$ (200 cm²).

Otherwise condensation can form, causing damage to the coffee system or the surrounding cabinets.

Installation

Make sure no power is supplied to the unit. The same applies in the event of disassembly!

When built into cabinetry, only use the coffee machine in ambient temperatures between +50°F/10°C and +100°F/38 °C.

You will need two Allen wrenches size 3 and 5 for the installation.

To align the unit door flush with the kitchen cabinetry, there must be a sealing strip around the installation recess; otherwise, a sealing strip must be put in place around the unit.

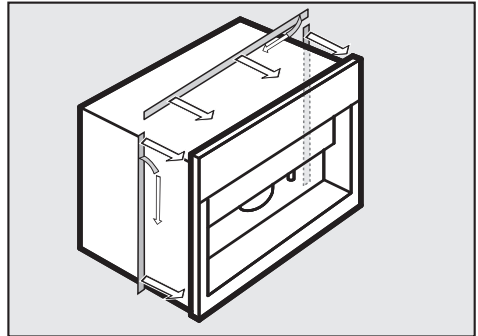

- If there is no sealing strip around the installation recess, stick the Miele sealing strip onto the unit from the back before putting it into the recess. The sealing strip is available from Miele.

Tip: A place to set down the coffee machine at the level of the installation recess is helpful. This makes it easier for you to install the unit's electrical and water connections.

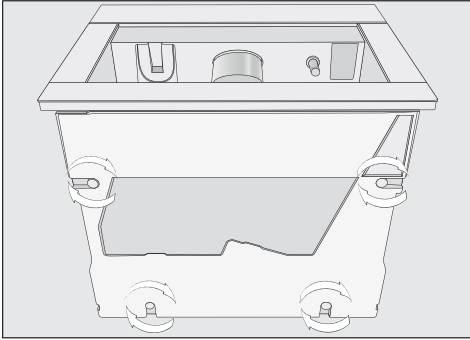

- Unscrew the four feet on the underside of the unit by about 1/16" (2 mm) using the larger Allen wrench.

The feet can be unscrewed by up to 3/8" (10 mm).

- Connect the unit to the water supply (see "Plumbing").
- Connect the unit to the electrical supply.
- Insert the coffee machine all the way into the installation recess.

When inserting the unit into the recess, make sure the electrical and water supply connections are not damaged.

- Check if the coffee machine is centered and straight in the installation recess. If not, align the unit using the four feet.

The coffee machine is delivered with four M5 Allen head screws that you can use to align and fasten the unit in the installation recess.

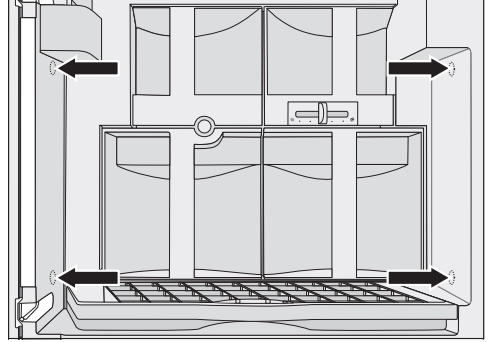

- Open the door and partially tighten the screws.
- Align the unit by carefully adjusting the lower Allen head screws until the unit is centered in the installation recess.
- To secure the unit in the cabinet, tighten the upper Allen head screws by hand.

Installation

Adjusting the door hinges

If the door cannot be opened or closed easily after installation, you will have to align the door (TX 20):

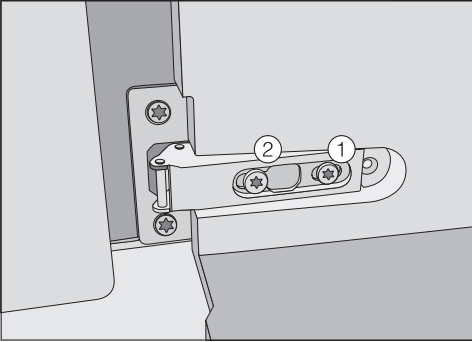

- To adjust the door flush with the front of the cabinet, turn the screw ①.
- To adjust the door horizontally and vertically, turn the screw ②.

RemoteVision (optional accessory)

Miele's RemoteVision Wi-Fi technology creates a 'virtual link' between your appliance and our monitoring center. If a fault occurs, Miele's client service center will be notified and contact you, or another trusted individual identified on your call roster, in order to gain access to your appliance to fix the problem.

For information on set-up and installation of the RemoteVision module see the "Installation" section of this manual.

Be sure your wireless system meets the following requirements

- A wireless router that supports an IEEE 802.11b/g protocol
- Windows XP® or newer operating system, Mac® OS X 10.3 or higher
- Cable or DSL modem
- Microsoft® Internet Explorer 6 or higher, Safari 2.0 or higher, Firefox 1.5 or higher

* Please note that each wireless router manufacturer supplies their own device drivers and setup programs. Due to the differences in manufacturers, exact router setup instructions are not included in this manual. Wording and instructions may vary.

Copyright and licenses

Miele uses software to operate and control the coffee system.

This product contains Adobe® Flash® Player software under license from Adobe Systems Incorporated, Adobe Macromedia Software LLC. Adobe and Flash are registered trademarks of Adobe Systems Incorporated.

The proprietary rights of Miele and other relevant software suppliers (e.g. Adobe) must be respected.

Miele and its suppliers reserve all rights to the software components.

In particular, the following are prohibited:

- Copying and distribution,
- Modifications and derivations,
- DE compilation, reverse engineering, disassembling and other such software reductions.

An overview of the integrated Open Source components and a copy of the current license can be obtained at www.miele.com/device-software-licences. You will need to enter the specific product name.

Please have the model and serial number of your appliance available before contacting Technical Service.

U.S.A.

Miele, Inc.

National Headquarters

9 Independence Way
Princeton, NJ 08540
Phone: 800-843-7231
609-419-9898
Fax: 609-419-4298
www.mieleusa.com

Technical Service & Support Nationwide

Phone: 800-999-1360
Fax: 888-586-8056
TechnicalService@mieleusa.com

Miele

Canada

Importer
Miele Limited

Headquarters and Miele Centre

161 Four Valley Drive
Vaughan, ON L4K 4V8
www.miele.ca

Customer Care Centre

Phone: 800-565-6435
905-532-2272
customercare@miele.ca

Germany

Manufacturer
Miele & Cie. KG
Carl-Miele-Straße 29
33332 Gütersloh



CVA 6805